

Etanchéité à l'eau* EN 1027 - EN 12208

Classe
Obtenu



Pression air	0 Pa	50 Pa	100 Pa	150 Pa	200 Pa	250 Pa	300 Pa	450 Pa	600 Pa	750 Pa	900 Pa	1050 Pa	1200 Pa	1350 Pa	1500 Pa
Km/h	0	32	45	55	64	72	78	96	111	126	138	149	159	169	178
Classe	-	1A	2A	3A	4A	5A	6A	7A	8A	E750	E900	E1050	E1200	E1350	E1500

--

Perméabilité à l'air* EN 1026 - EN 12207

Classe
Obtenu



Pression vent	150 Pa	300 Pa	450 Pa	600 Pa
Classe	1	2	3	4

-

Resistance à la charge du vent* EN 12211 - EN 12210

Classe
Obtenu



Pression air	400 Pa	800 Pa	1200 Pa	1600 Pa	2000 Pa	>2000 Pa
Flessione	A("1/150)		B("1/200)		C("1/300)	
Classe	1	2	3	4	5	Exxx

--

* Fenêtre à 2 vantaux, dimensions LxH XXXX X XXXX mm

Rapport d'Essai n° XXXX-CPR-RPXXX du

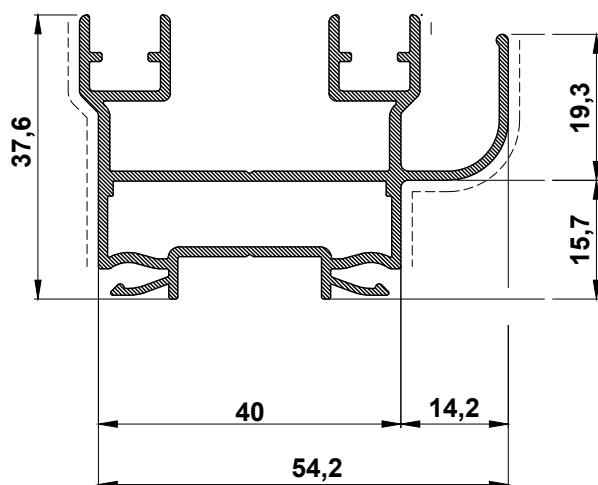

C.4102

POIDS [Kg/m] 0,849
PERIMETRE [mm] 385

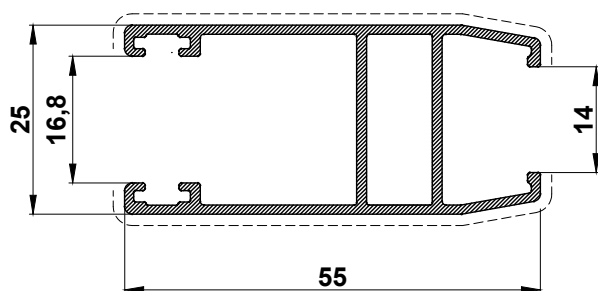

C.4202

POIDS [Kg/m] 0,597
PERIMETRE [mm] 288

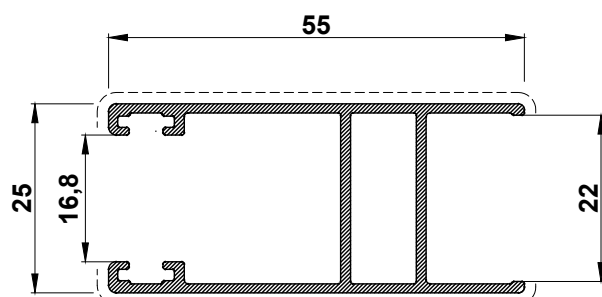

C.4203

POIDS [Kg/m] 0,578
PERIMETRE [mm] 277

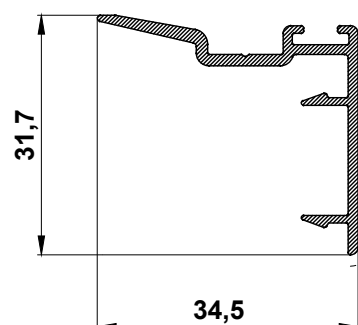

C.4200

POIDS [Kg/m] 0,297
PERIMETRE [mm] 168

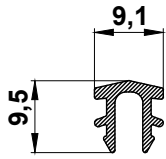

C.4100

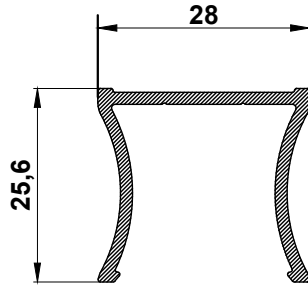

C.0280

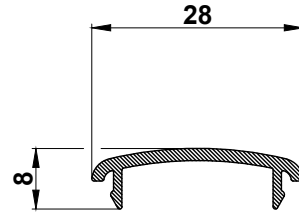

C.0281

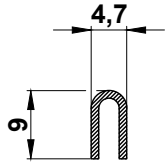

C.0181

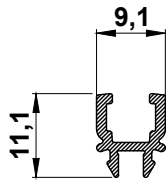

C.0180

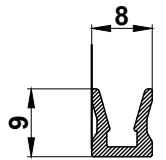

X.0010

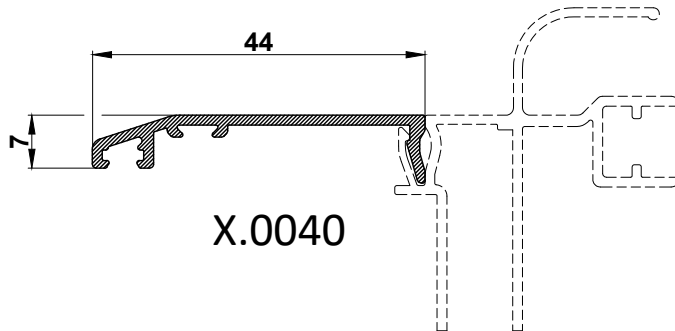

X.0040

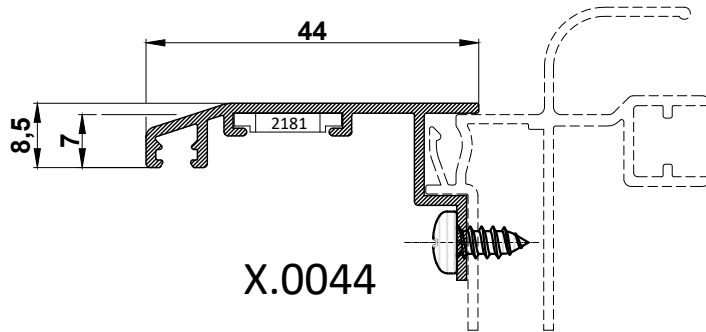

X.0044

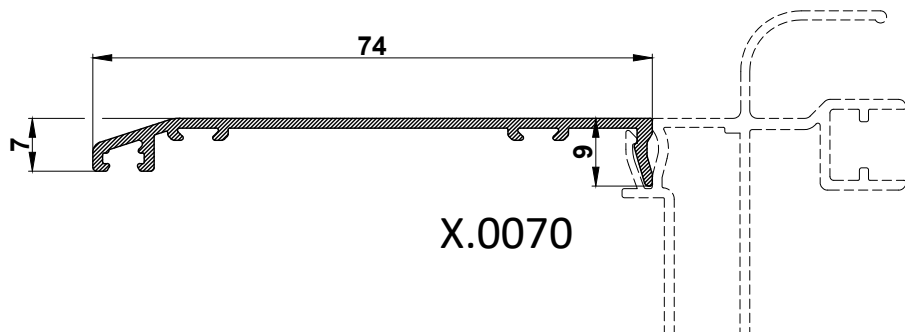



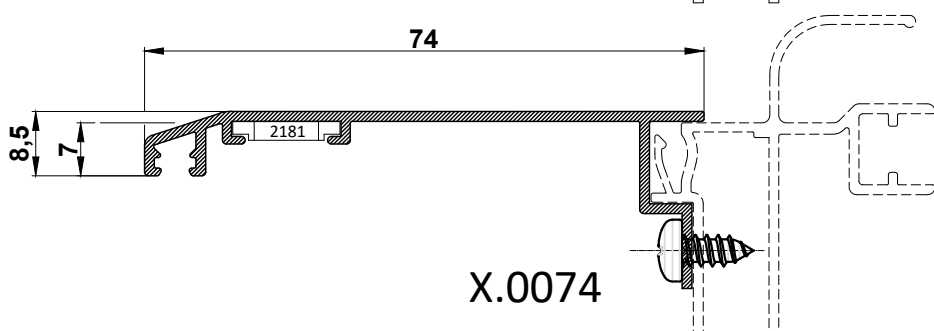

X.0070

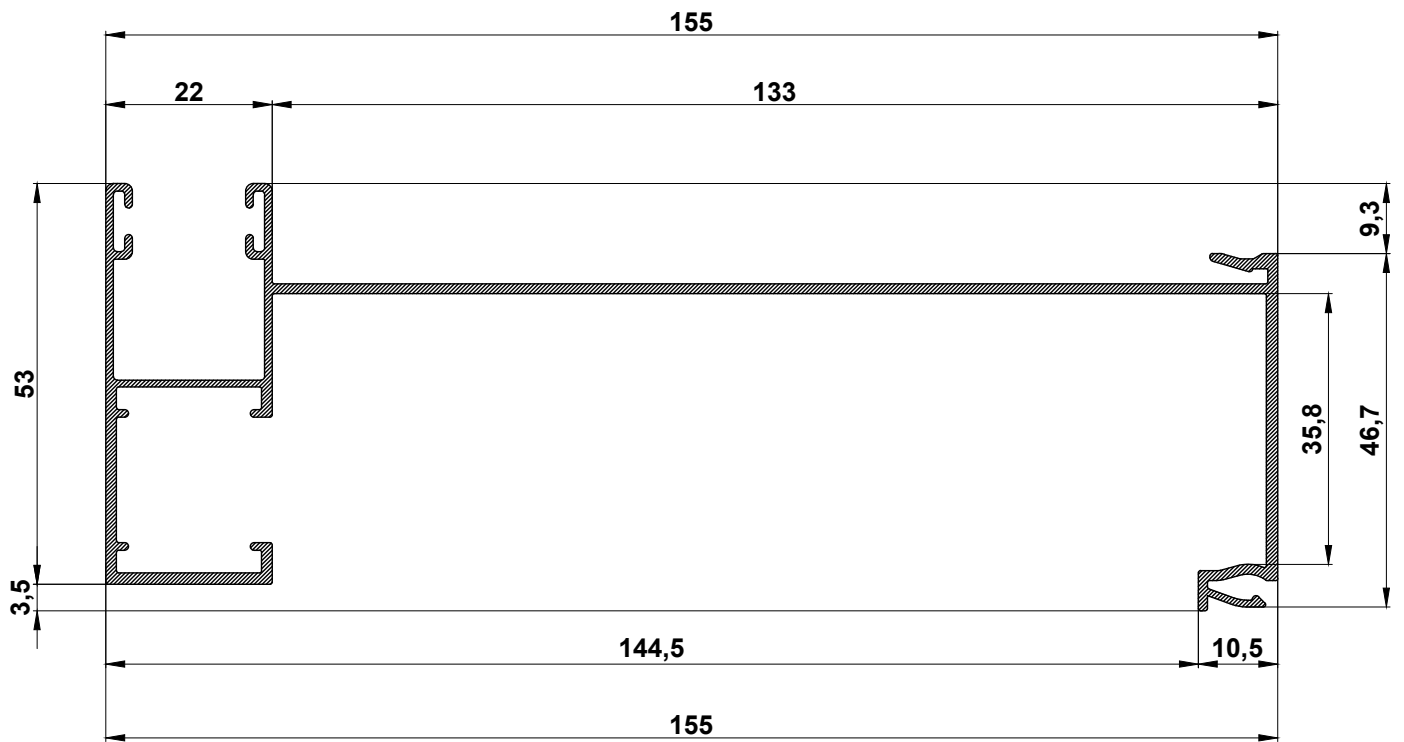
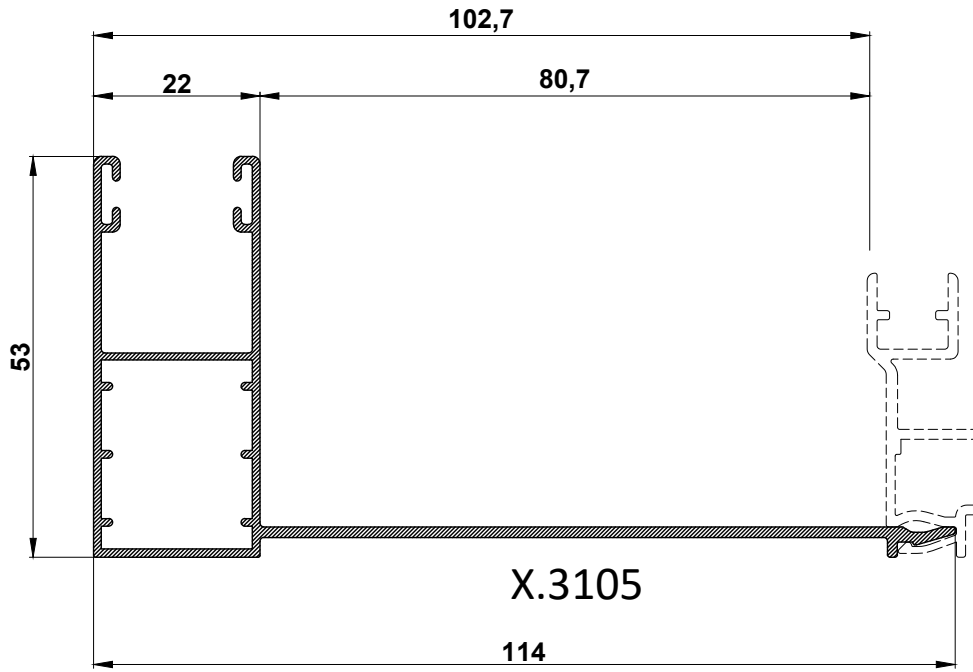



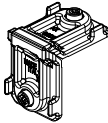

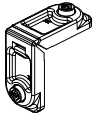
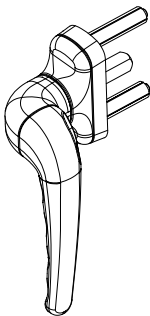
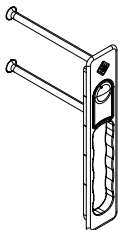
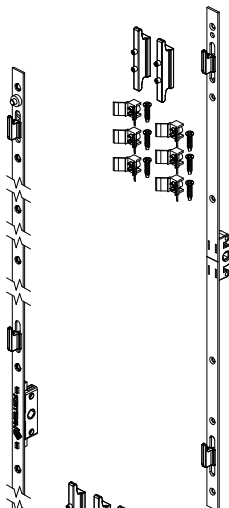
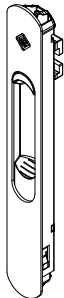
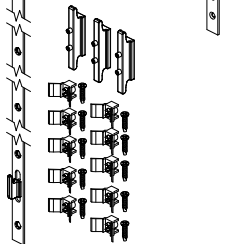
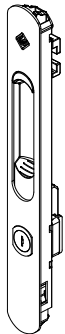
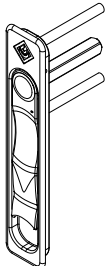

X.0074

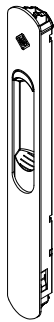
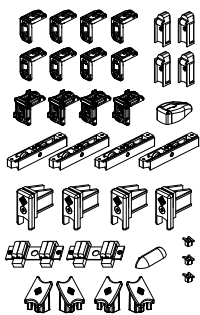
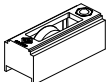
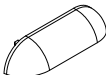
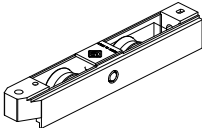
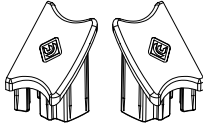
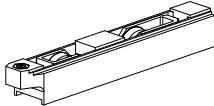

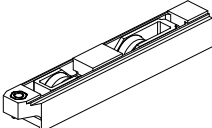
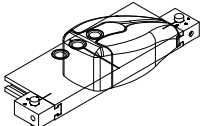
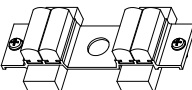
XP1.155

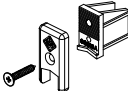
REF.	DESCRIPTION	REF.	DESCRIPTION
	0359 Equerre dormant		6397.10 Poignée de tirage
	0358 Equerre ouvrant		
	3076D Béquille à poignée 3076S "Ligne Comfort"		6397.11 Poignée de tirage extérieur
	PP6371B.21 Fast Lock a 2 points de fermeture (L=600mm) PP6372B.21 Fast Lock a 2 points de fermeture (L= 1000mm)		6450.1 Poignée à emboiter (mm 143) 6451.1 Poignée à emboiter (mm 165) 6452.1 Poignée à emboiter (mm 187) 6452 Poignée à emboiter (mm 187)
	PP6374B.21 Fast Lock a 3 points de fermeture (L=1800mm)		6452.3 Poignée a emboiter à clé (mm 187)
	6397.1 Poignée à emboiter v. secondaire		6477.41 Kit de fermeture pour poignées inner et innerclick
			6478T.3 Ergot en acier inox. Bec pli 1 mm L 29 mm

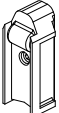
	REF.	DESCRIPTION		REF.	DESCRIPTION
	6451.20	Poignée de tirage encastrable à accrochage rapide (mm 165)		6620.188	Kit assemblage (90 Kg/vantail)
	6452.20	Poignée de tirage encastrable à accrochage rapide (mm 187)			
	6670.10	Chariots en nylon 1 roue (50 kg par vantail)		2145	Busette d'évacuation
	6656.5	Chariot double balancé registre (90 kg par vantail)		6843.31	Bouchon pour montant renforcé
	6667	Chariot double balancé registre (100 kg par vantail)		2133	Verin de pose
	6668	Chariot double balancé registre (180 kg par vantail)		6849.50	Gabarit pour béquille à Viper, butée pour coulissant
	6832.3	Cheville de joint central avec brosse		TC952.2	Bloc outil
	6827	Bouchon couvre-usinage			
	6841.4	Bague de vidange avec vanne			
	6812.1	Cheville amortisseur anti-déraillement			

NOMENCLATURE JOINTS



REF.	DESCRIPTION	REF.	DESCRIPTION
	AG1507 Joint brosse 6,9x5,5mm sans pinne centrale		CF-4113 Joint vitrage 2mm
	AG1500 Joint brosse 6,9x5,5mm avec pinne centrale		CF-4114 Joint vitrage 3mm
	CF-4112 Joint vitrage 1mm		

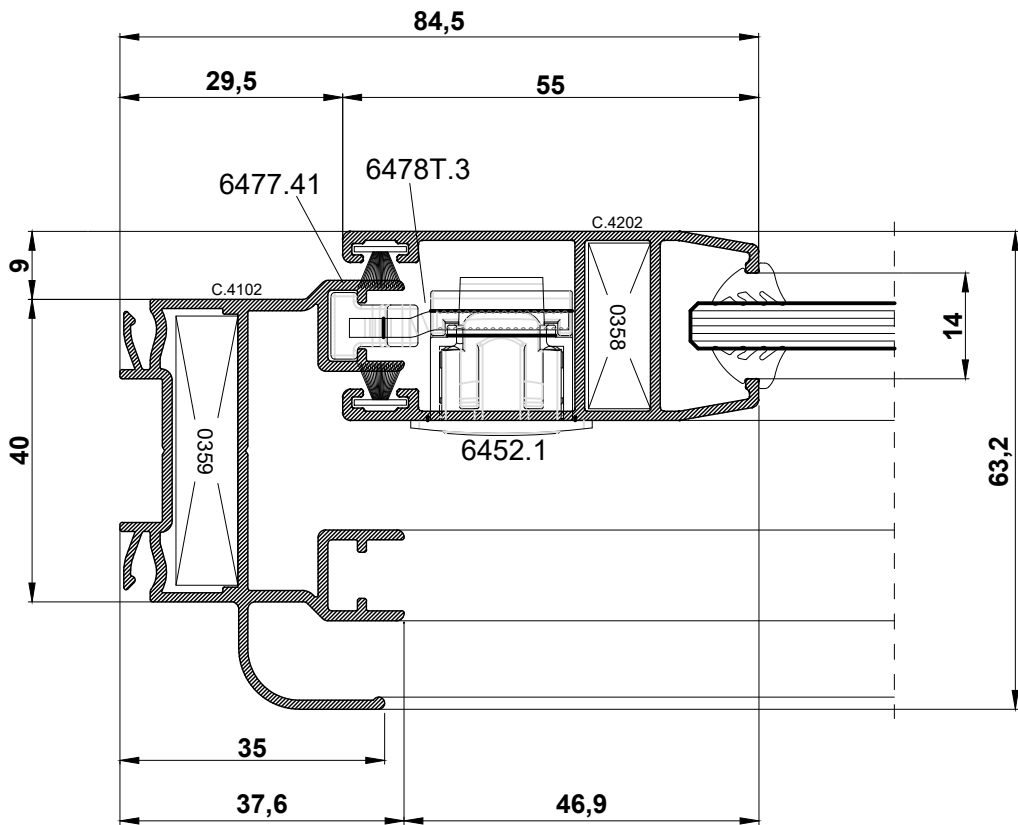
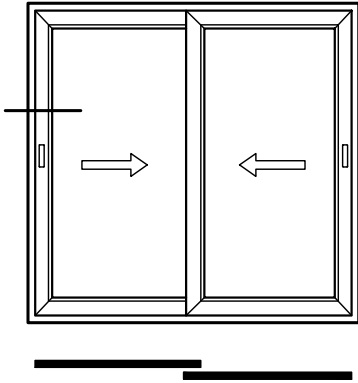

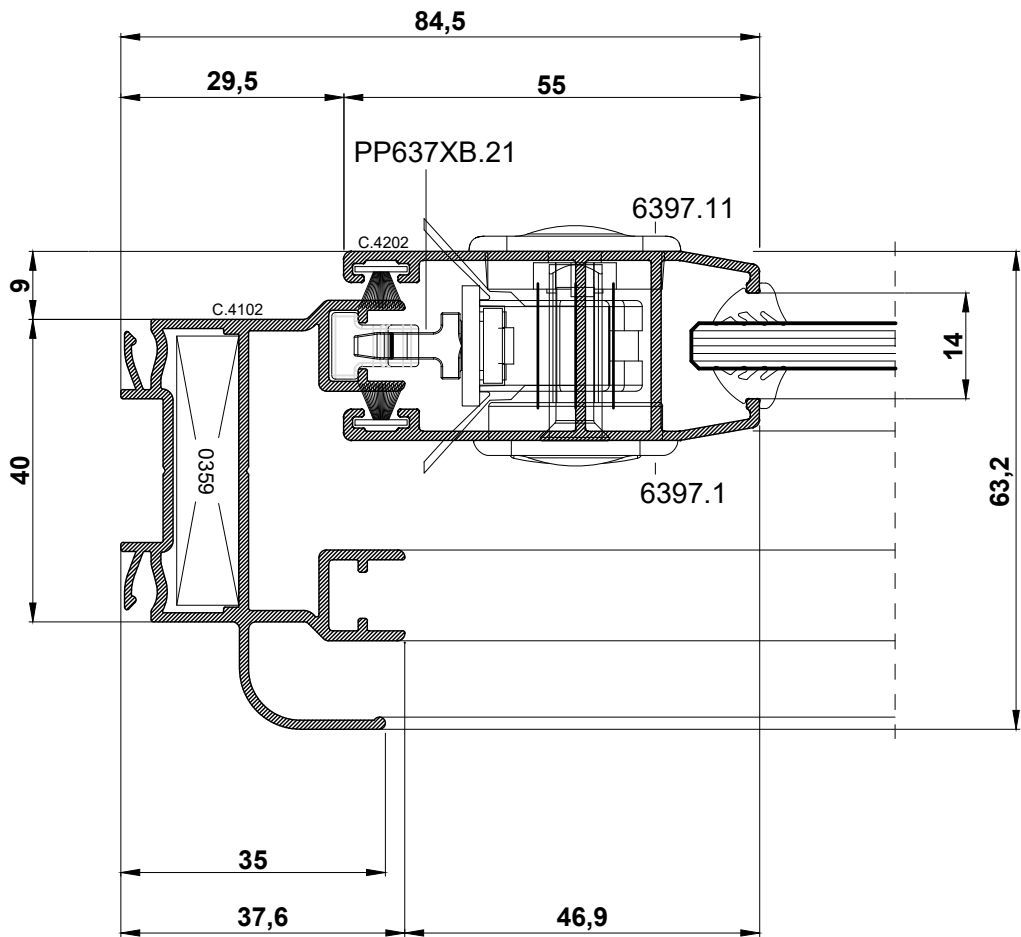
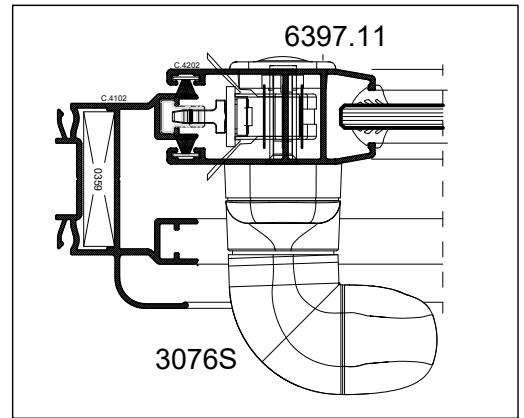
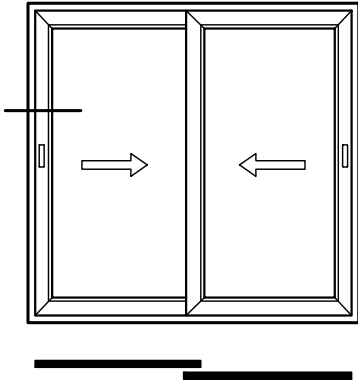

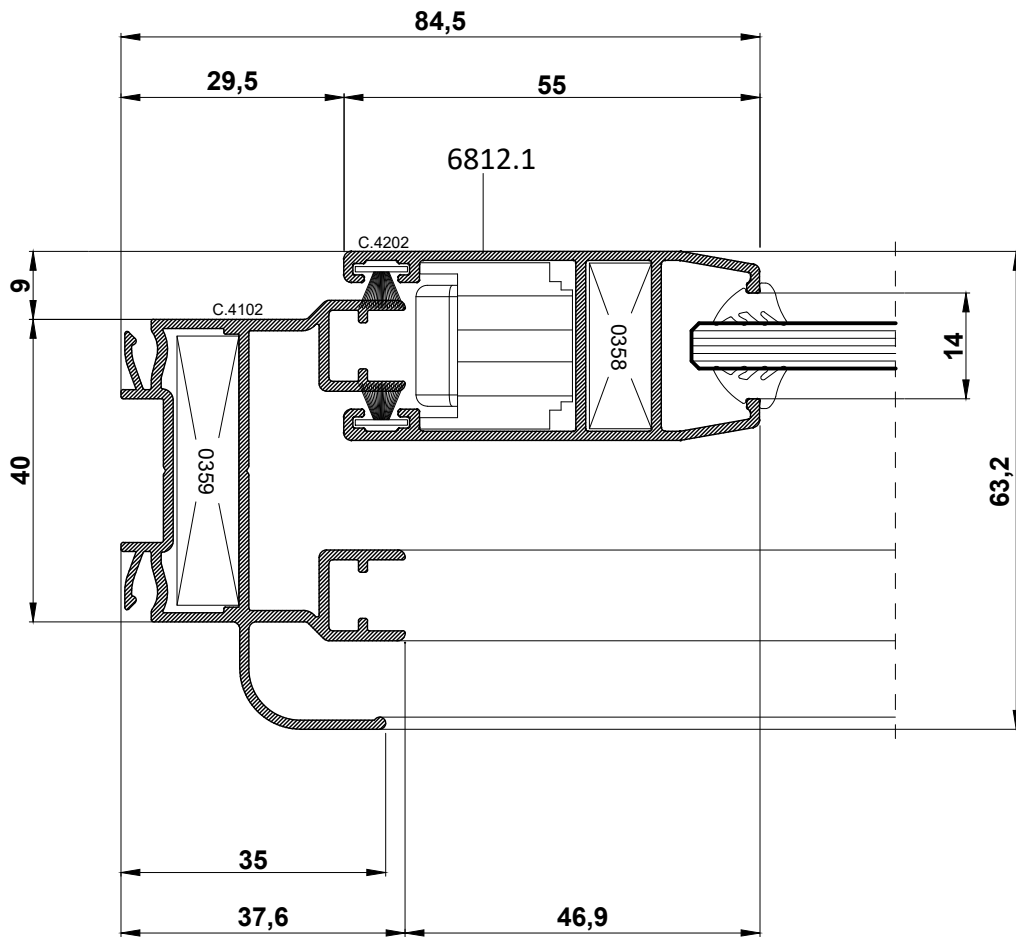
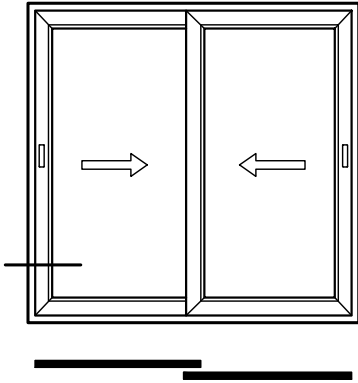

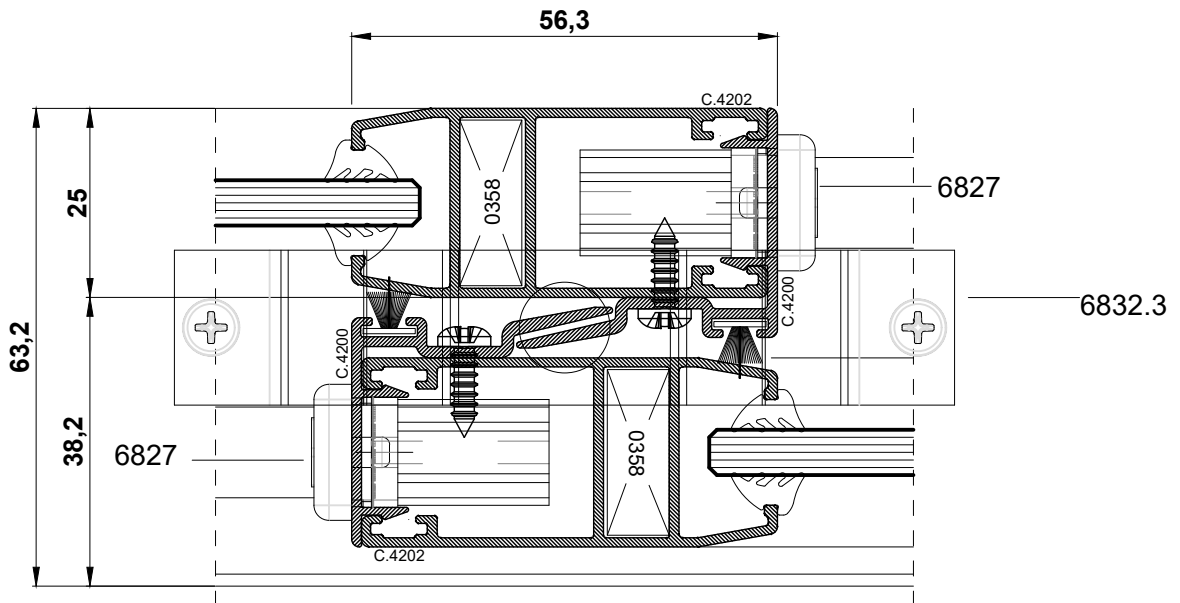
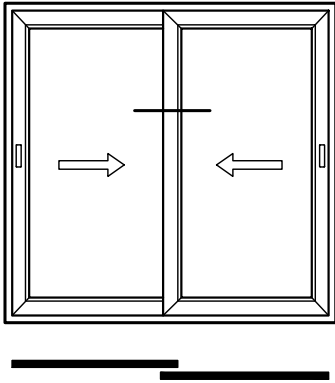

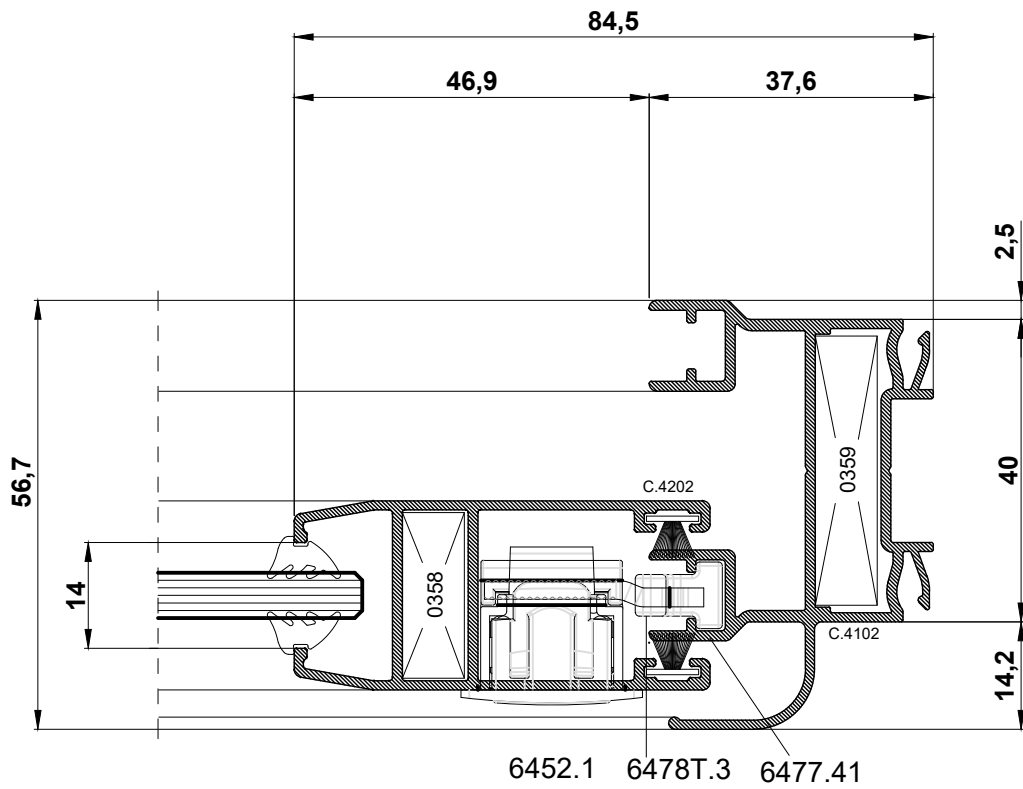
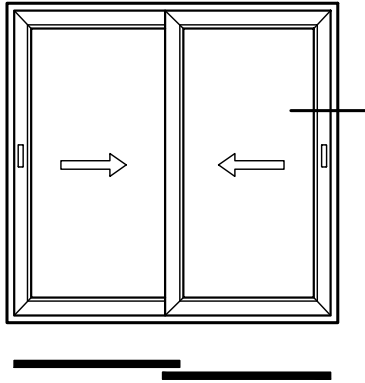

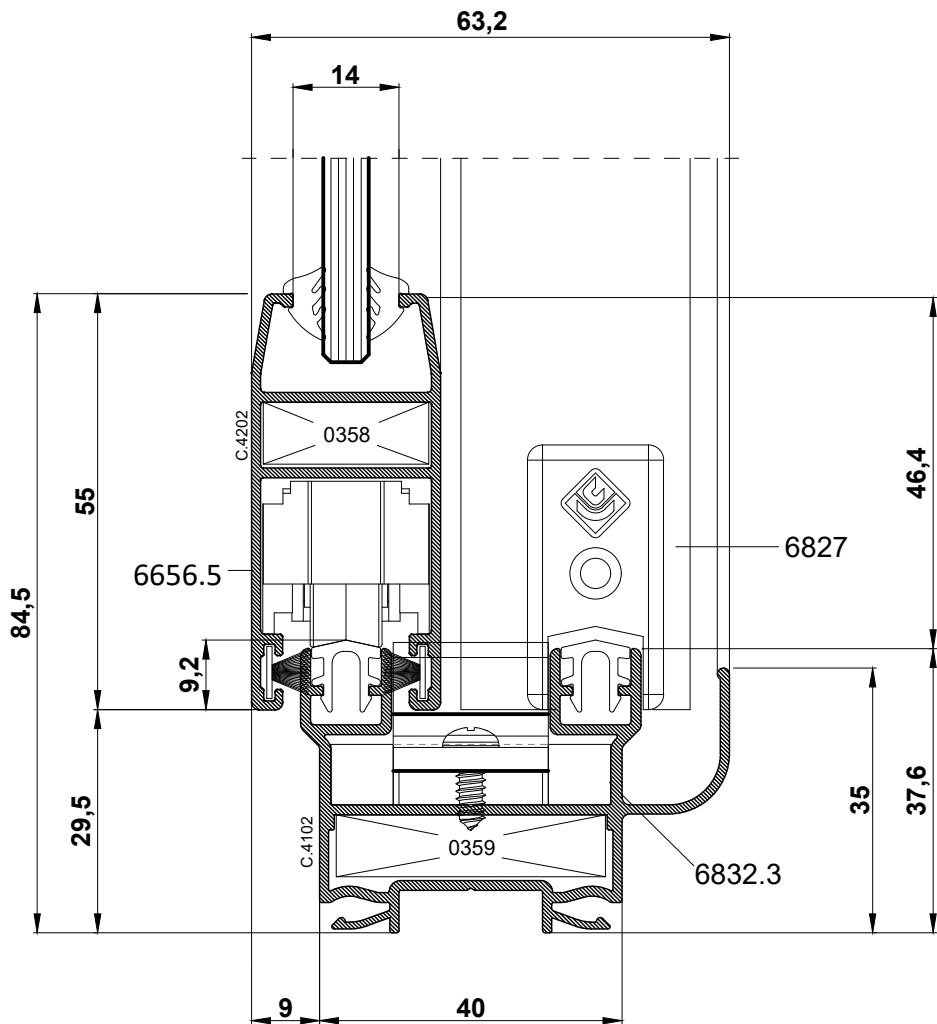
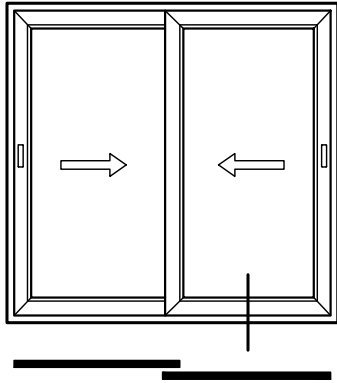

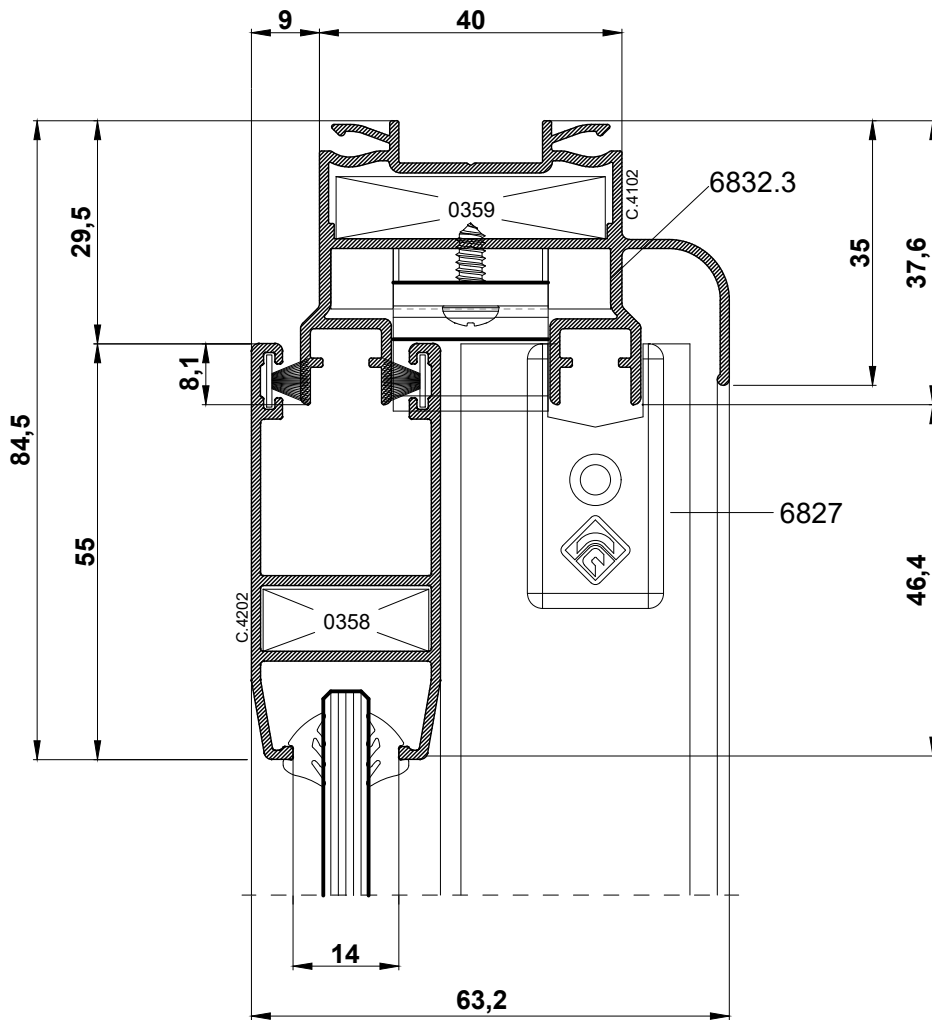
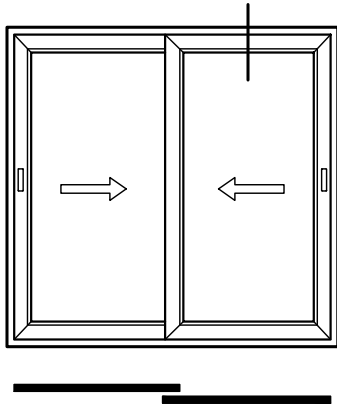

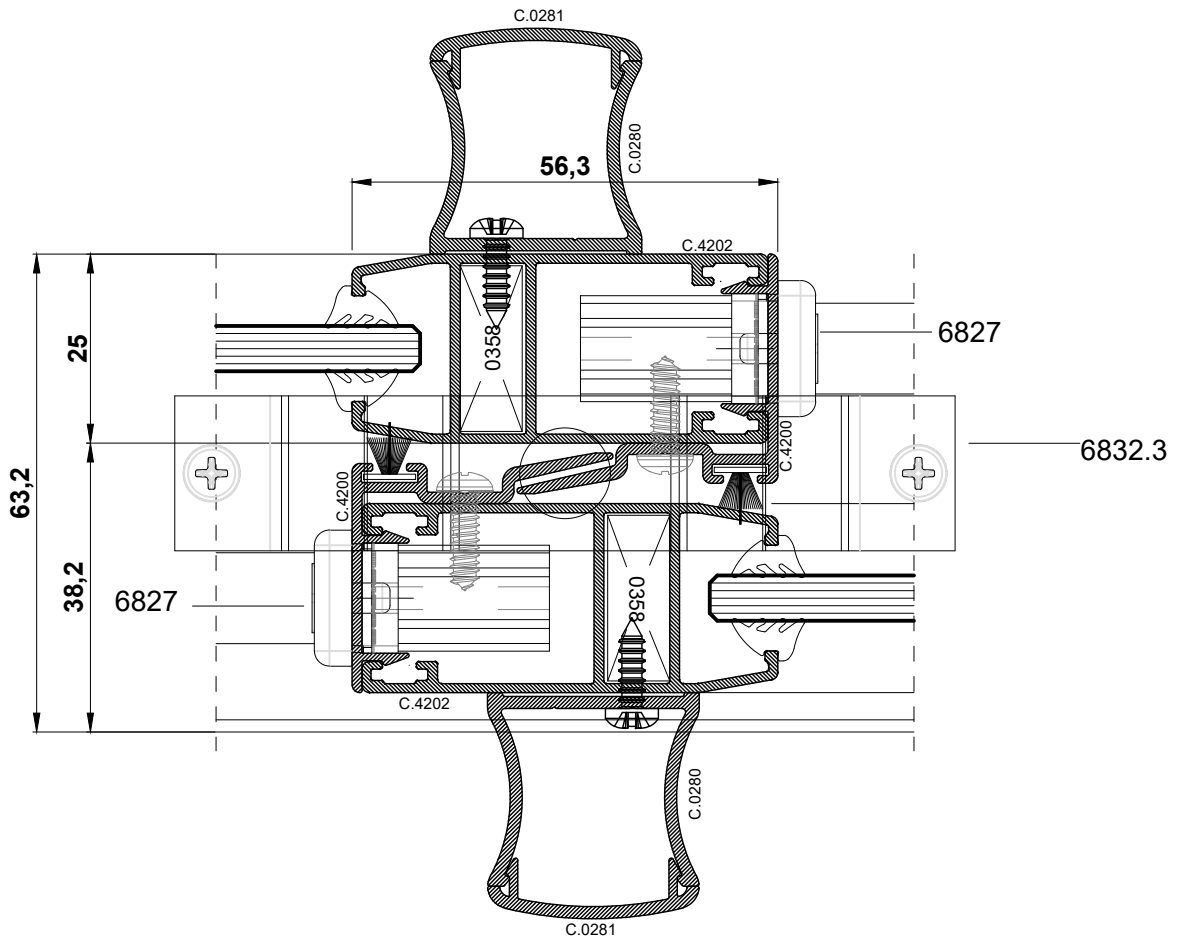
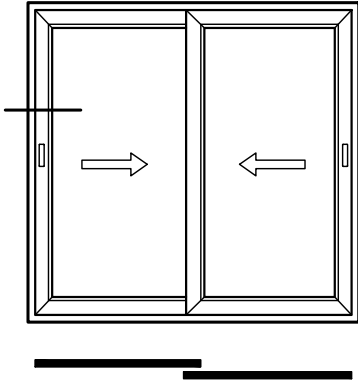

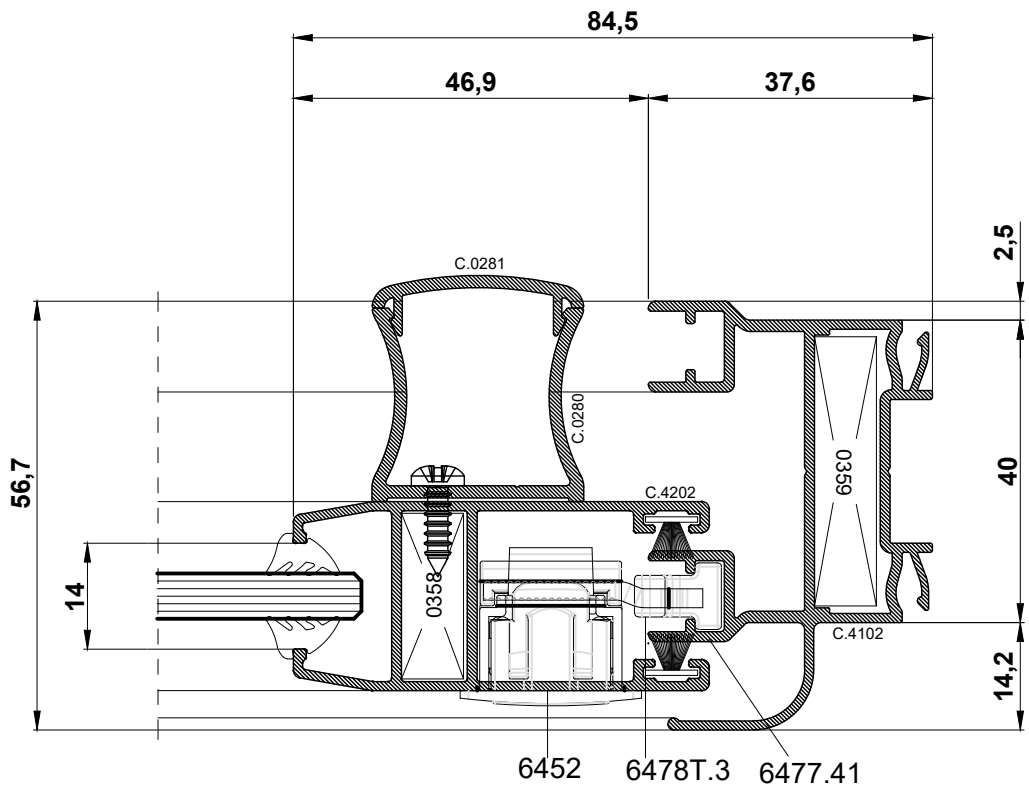
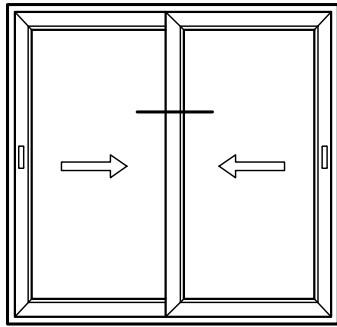

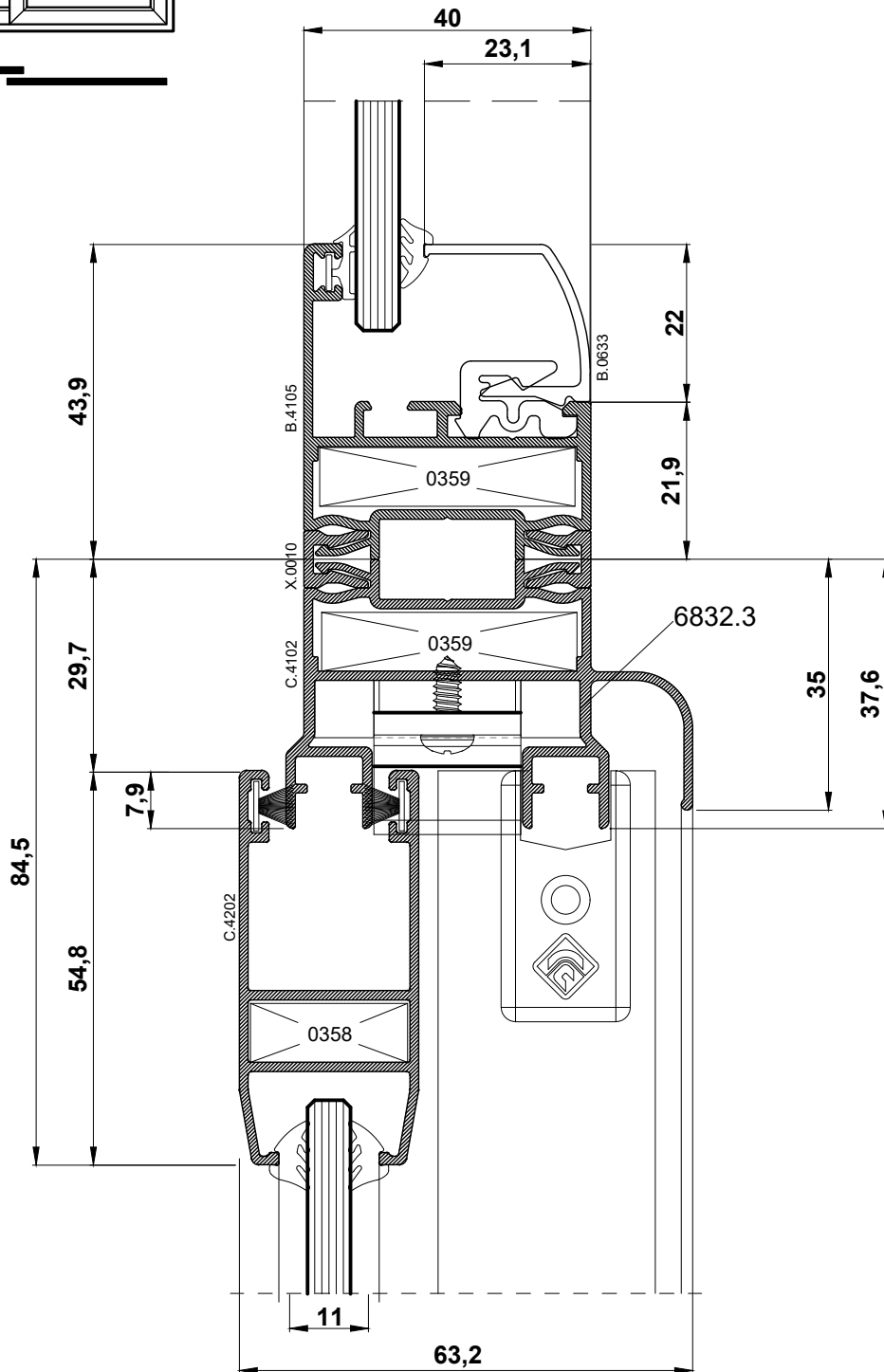
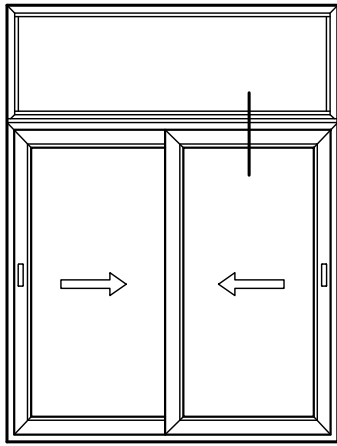

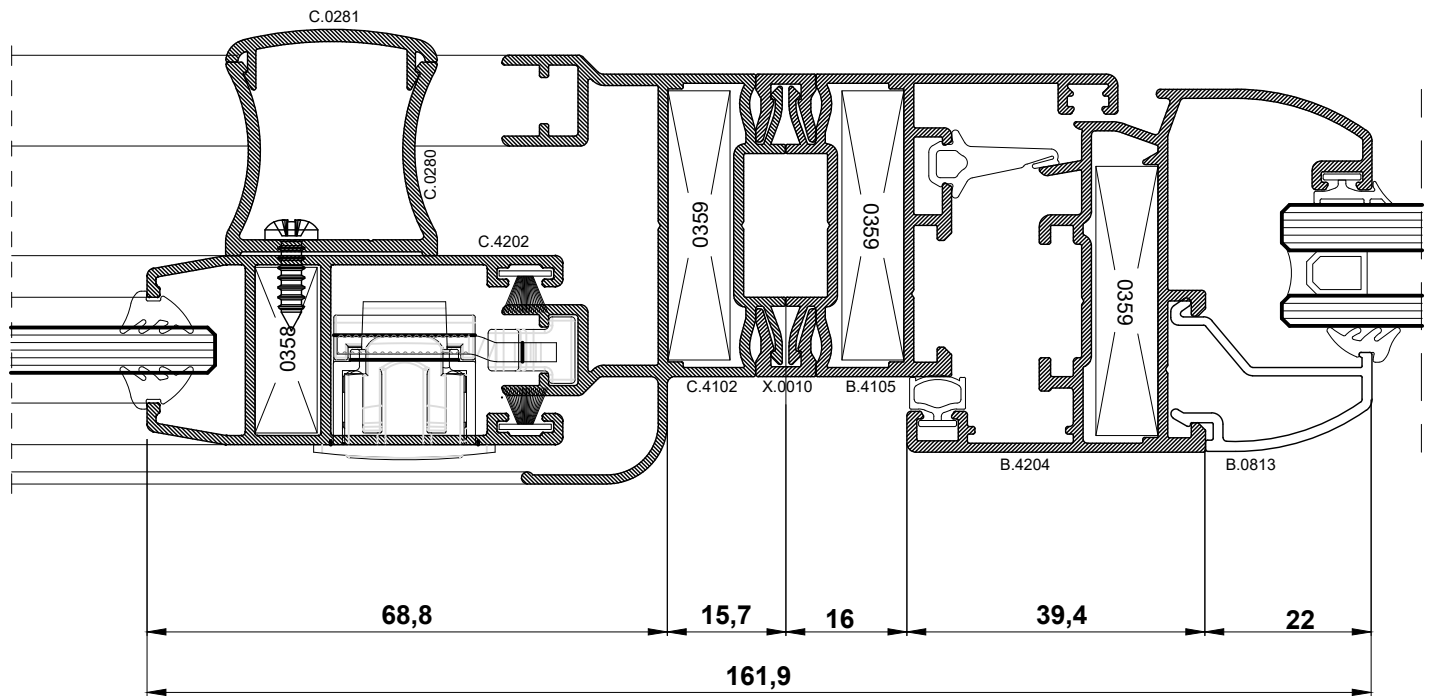
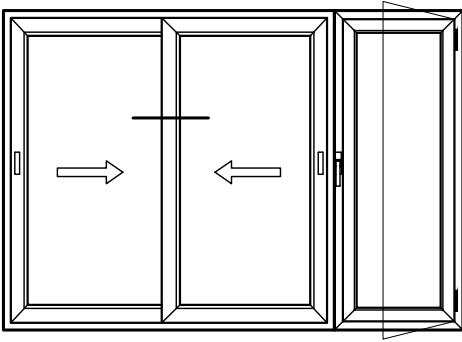

FENETRE 2 VANTAUX

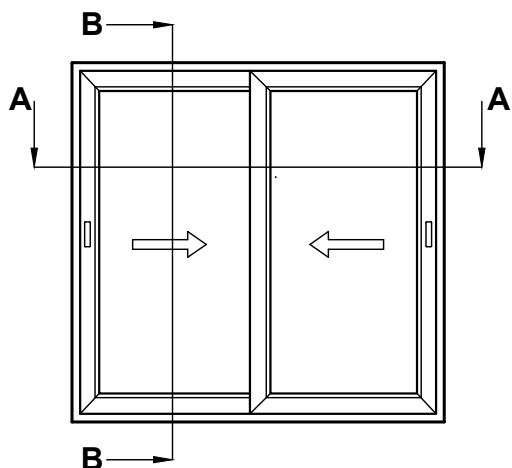

SEC. B-B

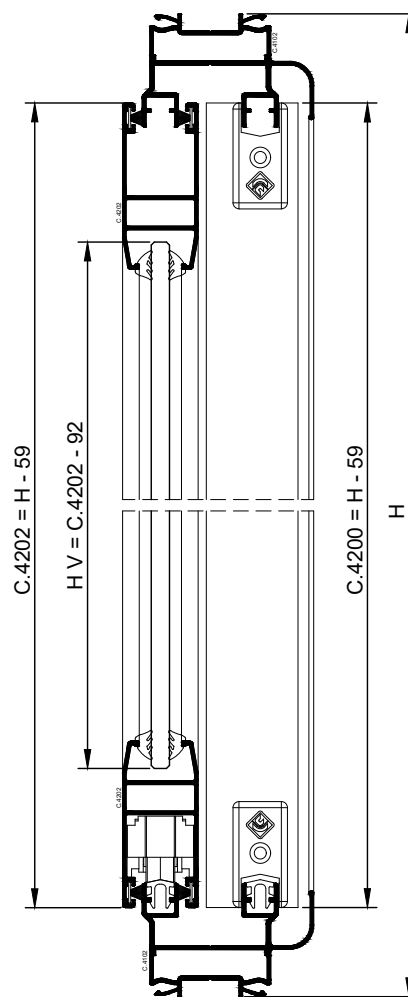

N.B.

Épaisseur vitrage considérée 6mm



L Vitrage = C.4202 - 92

H Vitrage = C.4202 - 92

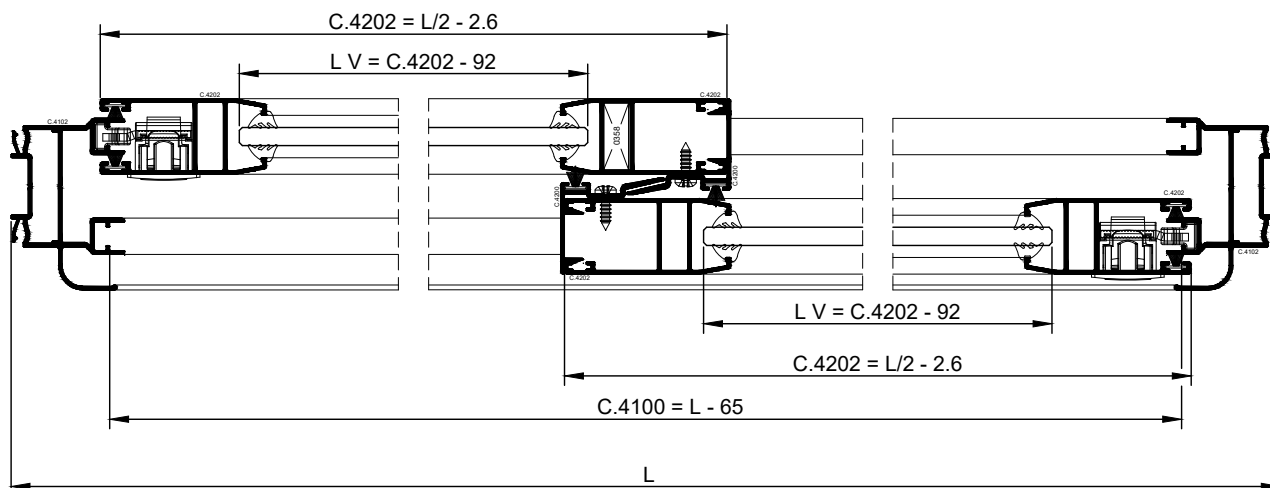
SEC. A-A

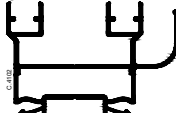
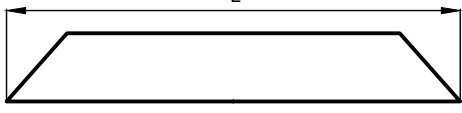
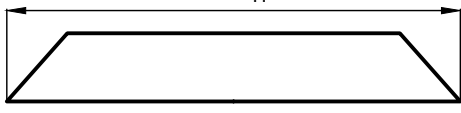
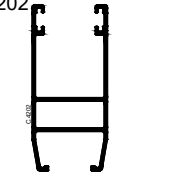
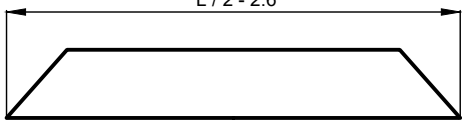
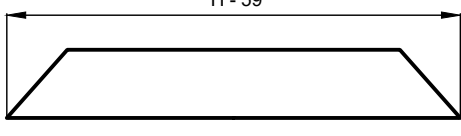
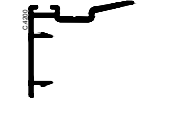
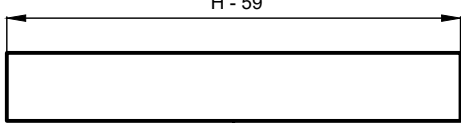

FENETRE 2 VANTAUX

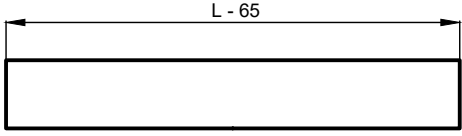
PROFILE	PCS	COUPE	PCS	COUPE
C.4102 	2	 L	2	 H
C.4202 	4	 L / 2 - 2.6	4	 H - 59
C.4200 			2	 H - 59
C.4100 	2	 L - 65		

ACCESSORIES

REF.	DESCRIPTION	N.	REF.	DESCRIPTION	N.
0359	Equerre dormant	4	6841.4	Bague de vidange avec vanne	3
0358	Equerre ouvrant	8	6832.3	Bloc étanchéité	2
6656.5	Galet double réglable	4	2145	Busette d'evacuation	2
6812.1	Fin de course et anti levage	4	6452.1	Poignée encastrable à accrochage rapide (mm 187)	2
6827	Bouchon montant central	4	6478T.3	Kit de fermeture pour poignées inner et innerclick	2
			6477.41	Kit de fermeture pour poignées inner et innerclick	2

JOINTS

REF.	DESCRIPTION	L	H	REF.	DESCRIPTION	L	H
AG1500	Brosse	8	4	CF- 4114	Joint vitrage	8	8
AG1507	Accrochage central		2				

LISTE DE DÉBITAGE



FENETRE 2 VANTAUX AVEC FIXE EN HAUTE

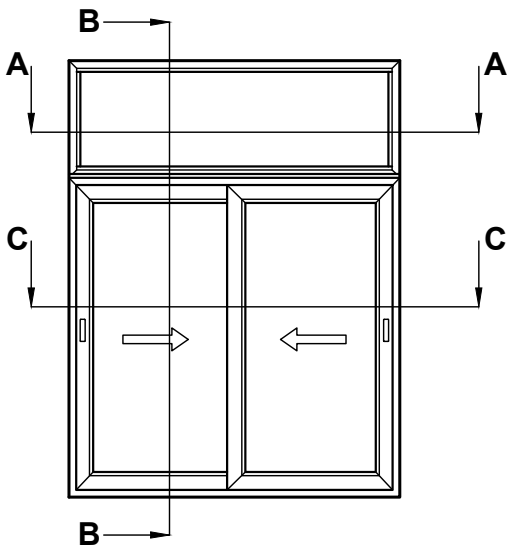

SEC. B-B

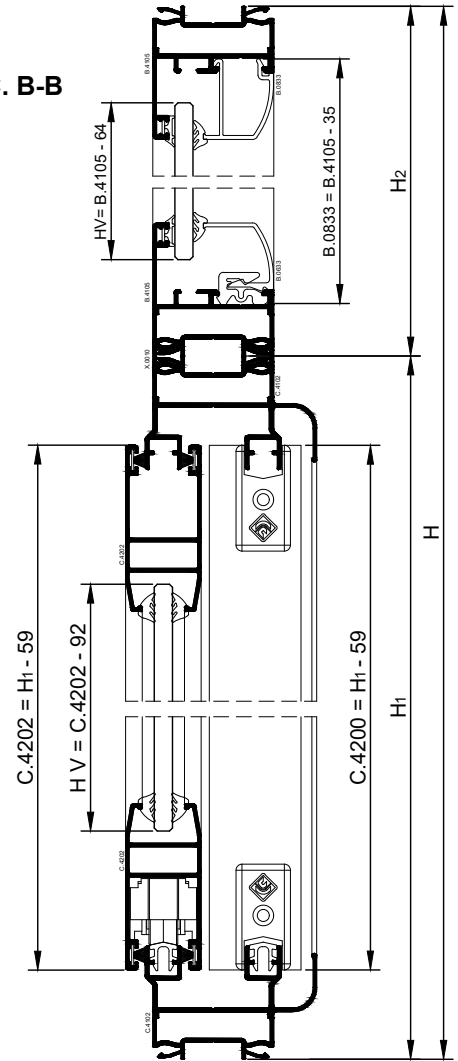

N.B.
Épaisseur vitrage considérée 6mm
L Vitrage = C.4202 - 92
H Vitrage = C.4202 - 92

Partie fixe
L Vitrage = B.4105 - 64
H2 Vitrage = B.4105 - 64



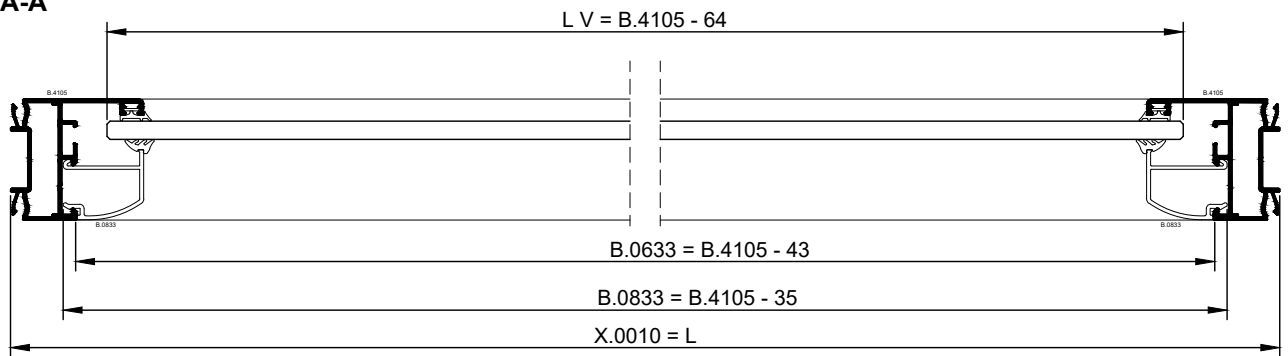



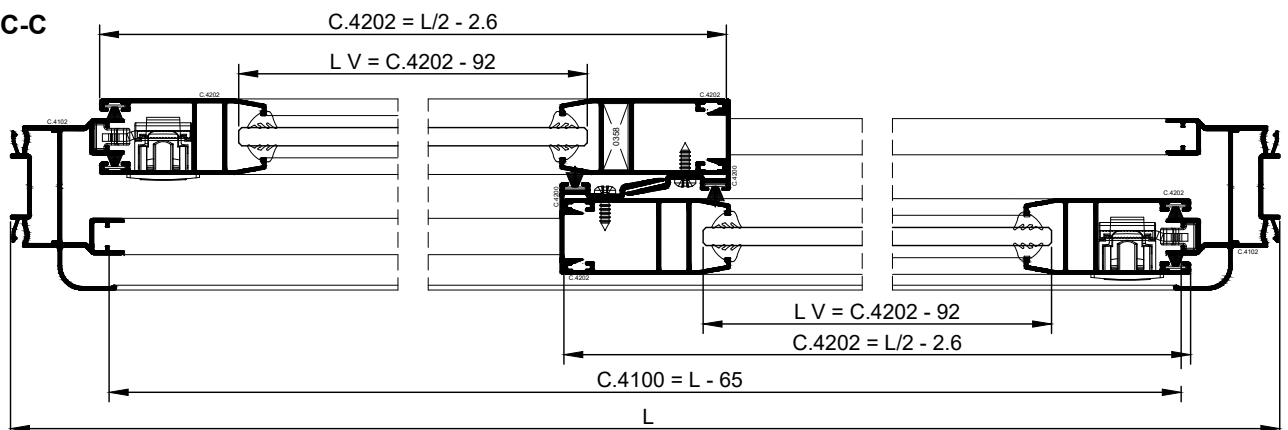

SEC. A-A

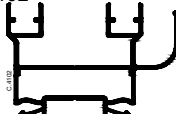
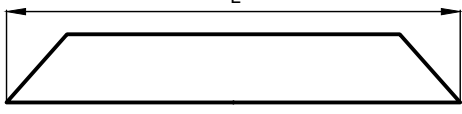
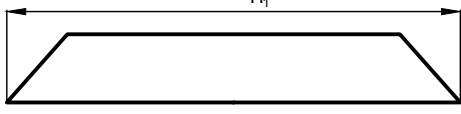
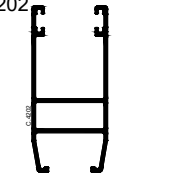
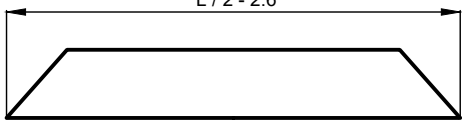
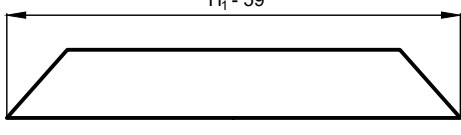
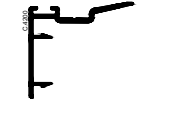
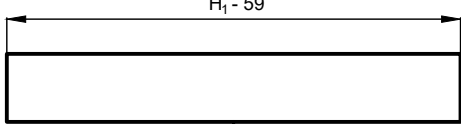

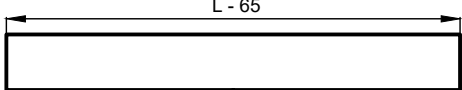
SEC. C-C

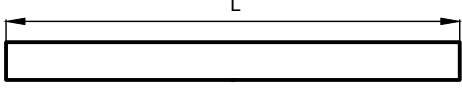
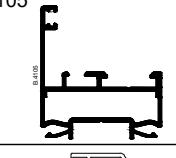
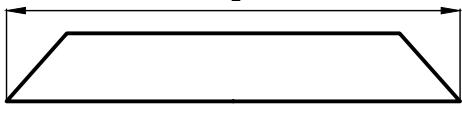
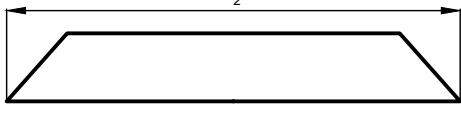

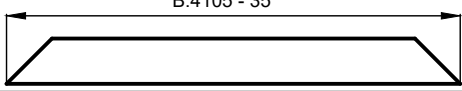
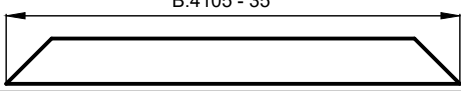
FENETRE 2 VANTAUX AVEC FIXE EN HAUTE

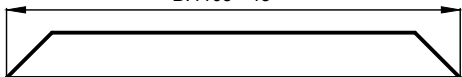
PROFILE	PCS	COUPE	PCS	COUPE
C.4102 	2	 L	2	 H ₁
C.4202 	4	 L / 2 - 2.6	4	 H ₁ - 59
C.4200 			2	 H ₁ - 59
C.4100 	2	 L - 65		
X.0010 	2	 L		
B.4105 	2	 L	2	 H ₂
B.0833 	1	 B.4105 - 35	2	 B.4105 - 35
B.0633 	1	 B.4105 - 43		

ACCESSORIES

REF.	DESCRIPTION	N.	REF.	DESCRIPTION	N.
0359	Equerre dormant	4	6832.3	Bloc étanchéité	2
0358	Equerre ouvrant	8	2145	Busette d'evacuation	2
6656.5	Galet double réglable	4	6452.1	Poignée encastrable à accrochage rapide (mm 187)	2
6812.1	Fin de course et anti levage	4	6478T.3	Kit de fermeture pour poignées inner et innerclick	2
6827	Bouchon montant central	4	6477.41	Kit de fermeture pour poignées inner et innerclick	2
6841.4	Bague de vidange avec vanne	3	0359	Equerre dormant (partie fixe)	4

JOINTS

REF.	DESCRIPTION	L	H1	REF.	DESCRIPTION	L	H1
AG1500	Brosse	8	4	CF4114	Joint vitrage	8	8
AG1507	Brosse central		2	CF4114	Vitrage interieur (partie fixe)	2	2 (H ₂)
				SY4-11	Vitrage exterior (partie fixe)	2	2 (H ₂)

EQUERRE

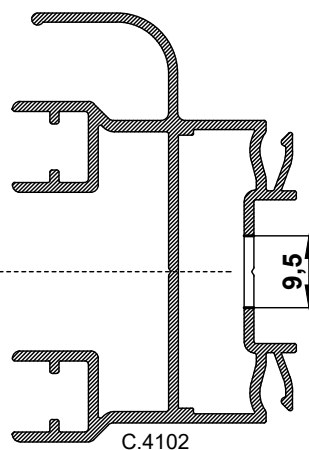
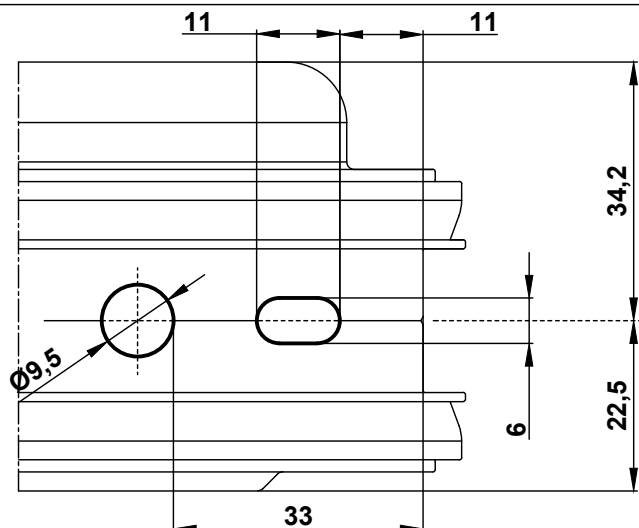

C.4102

0359

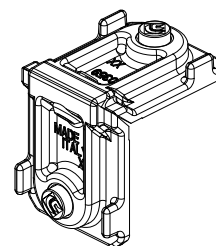

Outil : Bloc outil / Perceuse

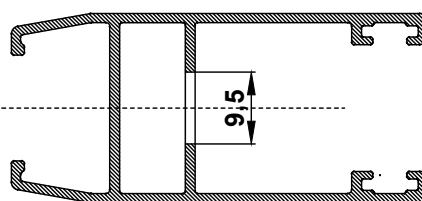
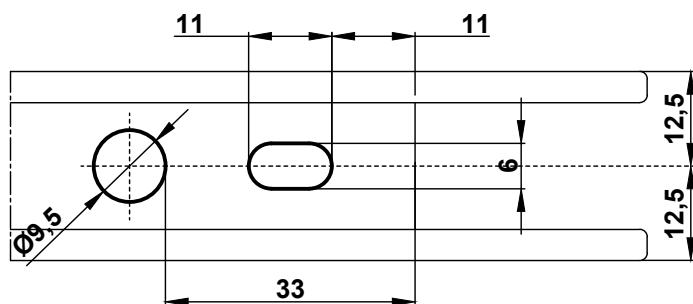

C.4202

0358

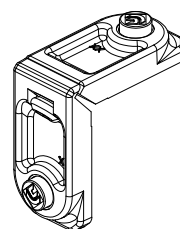

Outil : Bloc outil / Perceuse

BOUCHON MONTANT CENTRAL

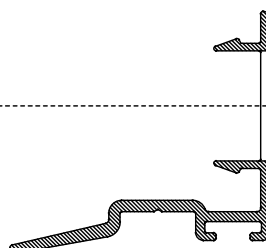
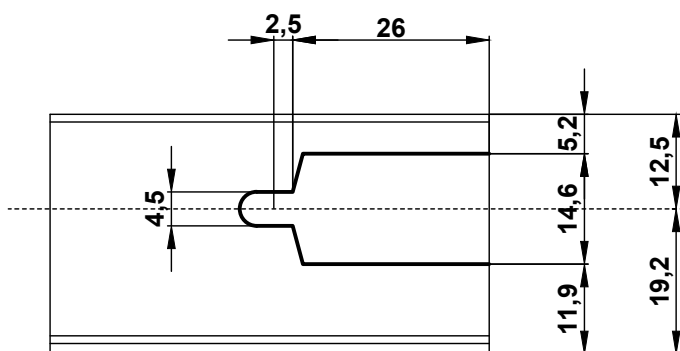

C.4200

6827

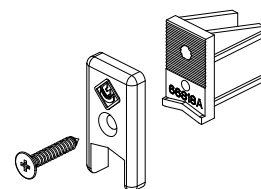

Outil : Bloc outil / Perceuse

POIGNEE

ART.	A
6452	187
6452.3	187
6452.1	187
6451.1	165
6450.1	143

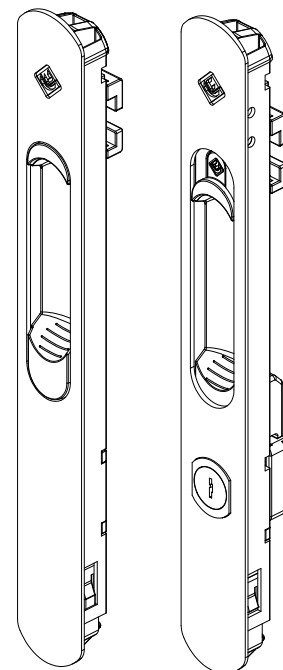
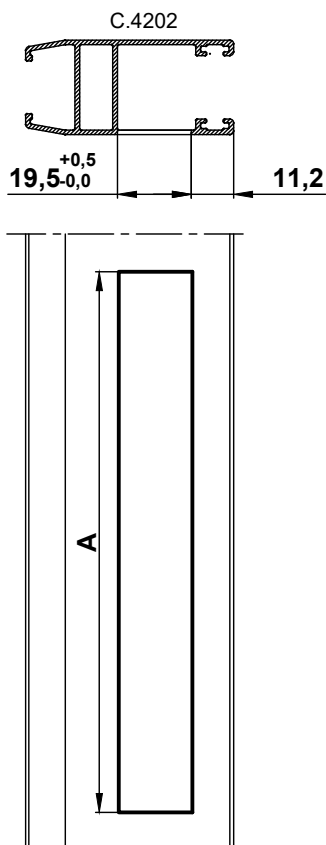

Outil : Bloc outil / Perceuse

PP637XB.21

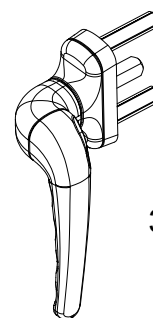
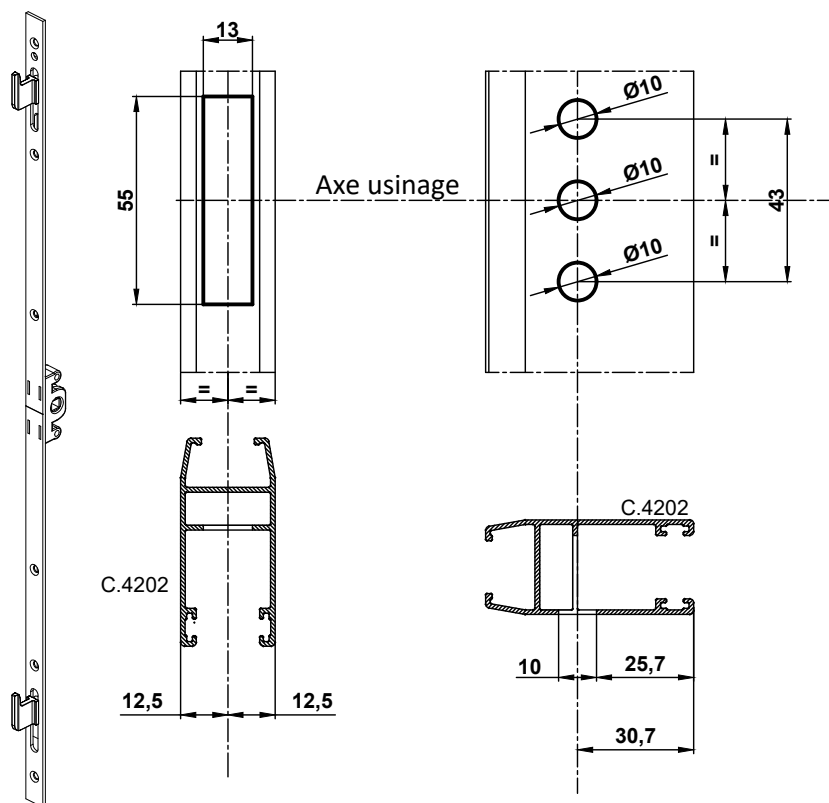

3076S

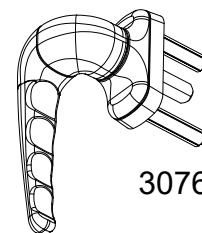

3076D

Outil : Bloc outil / Perceuse

POIGNEE

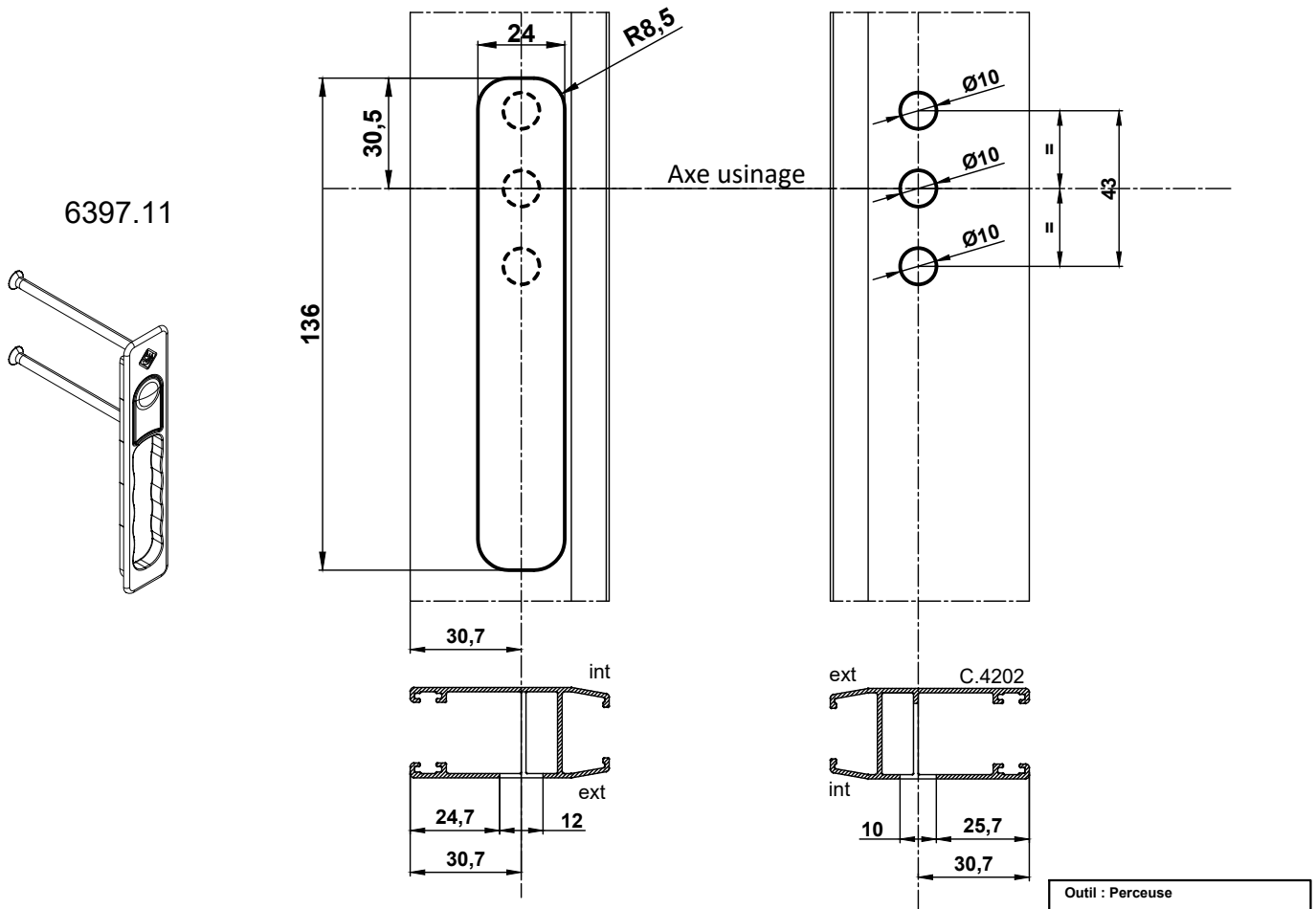

BOUCHON DRAINAGE

BUSETTE D'EVACUATION

