

**Etanchéité à l'eau\* EN 1027 - EN 12208**

Classe  
Obtenu



Pression air	0 Pa	50 Pa	100 Pa	150 Pa	200 Pa	250 Pa	300 Pa	450 Pa	600 Pa	750 Pa	900 Pa	1050 Pa	1200 Pa	1350 Pa	1500 Pa
Km/h	0	32	45	55	64	72	78	96	111	126	138	149	159	169	178
Classe	-	1A	2A	3A	4A	5A	6A	7A	8A	E750	E900	E1050	E1200	E1350	E1500

**8A**

**Perméabilité à l'air\* EN 1026 - EN 12207**

Classe  
Obtenu



Pression vent	150 Pa	300 Pa	450 Pa	600 Pa
Classe	1	2	3	4

**4**

**Resistance à la charge du vent\* EN 12211 - EN 12210**

Classe  
Obtenu



Pression air	400 Pa	800 Pa	1200 Pa	1600 Pa	2000 Pa	>2000 Pa
Flessione	A("1/150)	B("1/200)	C("1/300)			
Classe	1	2	3	4	5	Exxx

**B3/C2**

\* Fenêtre à 2 vantaux, dimensions LxH 1800X2195 mm

Rapport d'Essai n° 1994-CPR-RP1938 du 27 Novembre 2019

# NOMENCLATURE PROFILES



REF.	SECTION	POIDS Kg/m	PERIMÈTRE mm	$J_x = cm^4$	$J_y = cm^4$
B.0105		0,761	302	8,94	3,47
B.0125		1,014	366	14,40	19,89
B.0200		0,869	333	10,66	6,84
B.0204		0,931	370	14,92	7,12
B.0206		1,045	395	16,47	14,00
B.0208		0,843	320	11,53	5,00
B.0209		0,329	184		
B.0224		1,173	434	21,97	29,34
B.0226		1,173	434	20,59	29,34
B.0305		0,900	333	9,63	6,14
B.0325		1,096	389	13,83	23,32

# NOMENCLATURE PROFILES



REF.	SECTION	POIDS Kg/m	PERIMÈTRE mm	$J_x = cm^4$	$J_y = cm^4$
B.0326		1,779	488	15,00	14,9
B.0330		1,376	469	76,17	19,75
B.0331		0,353	197		
B.0332		0,473	228		
B.0613		0,174	89		
B.0623		0,191	99		
B.0633		0,244	129		
B.0713		0,256	149		
B.0723		0,267	155		
B.0733		0,317	183		
B.0813		0,230	141		

# NOMENCLATURE PROFILES



REF.	SECTION	POIDS Kg/m	PERIMÈTRE mm	$J_x = cm^4$   $J_y = cm^4$
B.0823		0,241	146	
B.0833		0,292	175	
X.0010		0,088	46	
X.0040		0,230	128	
X.0050		0,231	103	
X.0060		0,251	135	
X.0070		0,349	175	
X.0190		0,784	246	
X.2105		0,492	260	
X.3105		0,823	421	



# NOMENCLATURE PROFILES



REF.	SECTION	POIDS Kg/m	PERIMÉTRÈ mm	$J_x = cm^4$   $J_y = cm^4$
------	---------	------------	--------------	-----------------------------

XP1.155



1,20

705

XP2.185



1,31

765

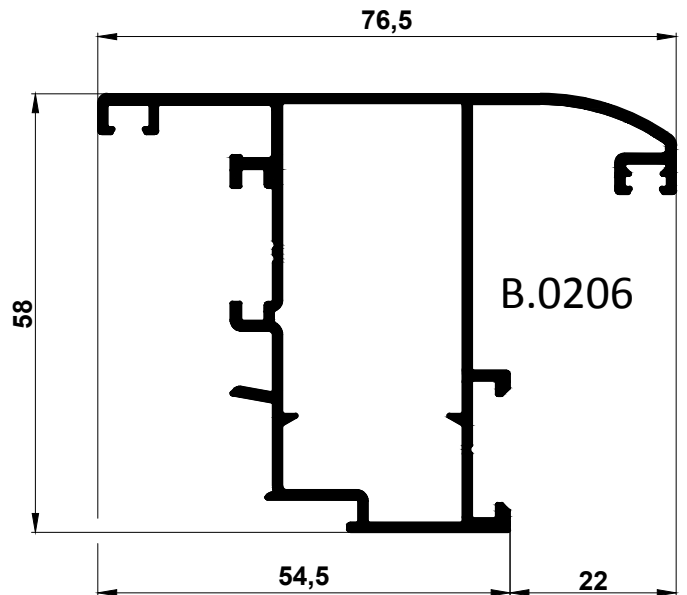
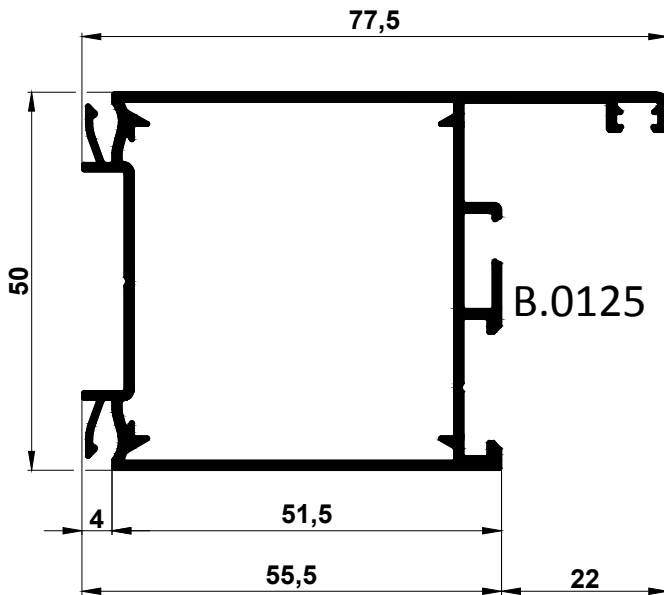
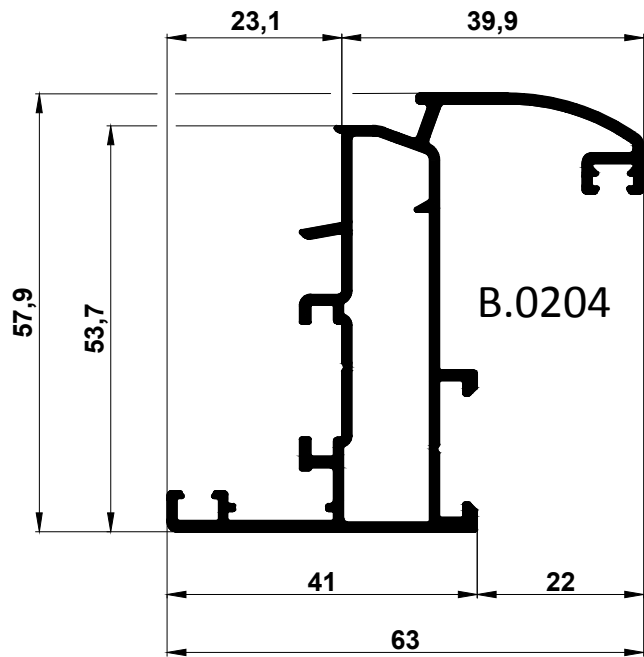
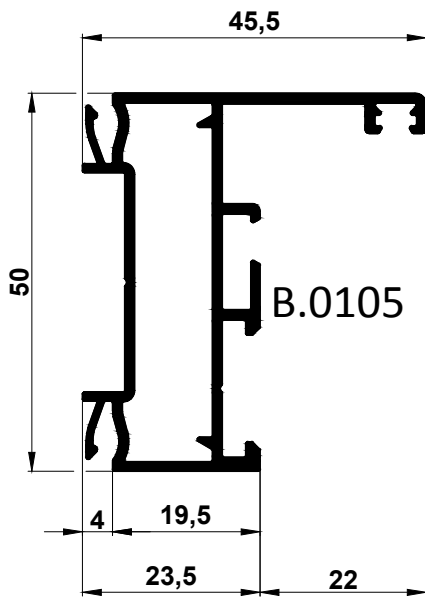

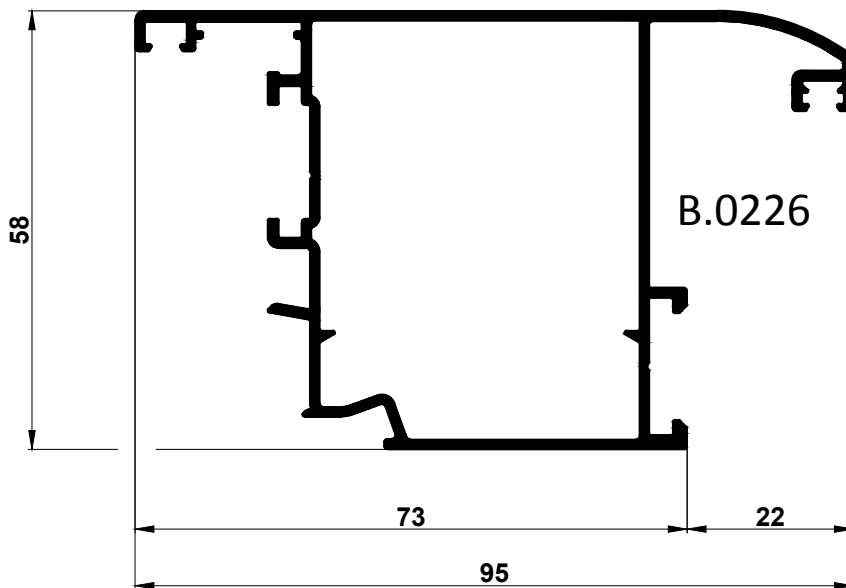
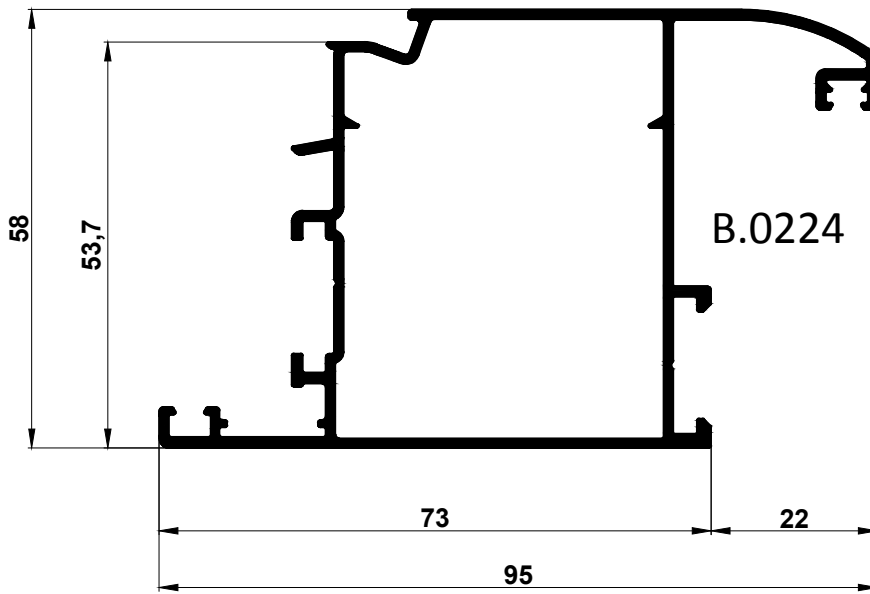

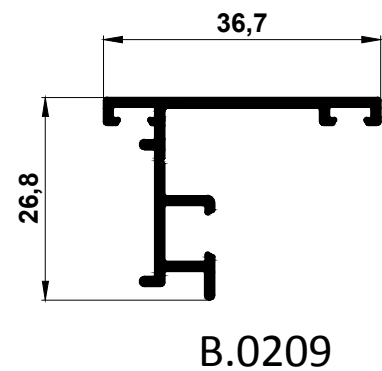
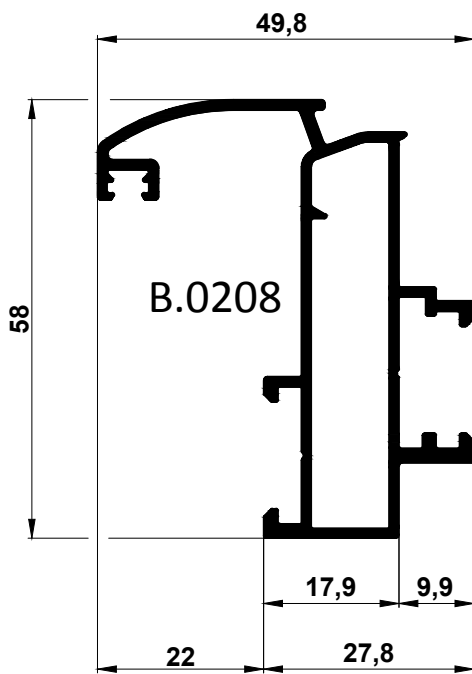
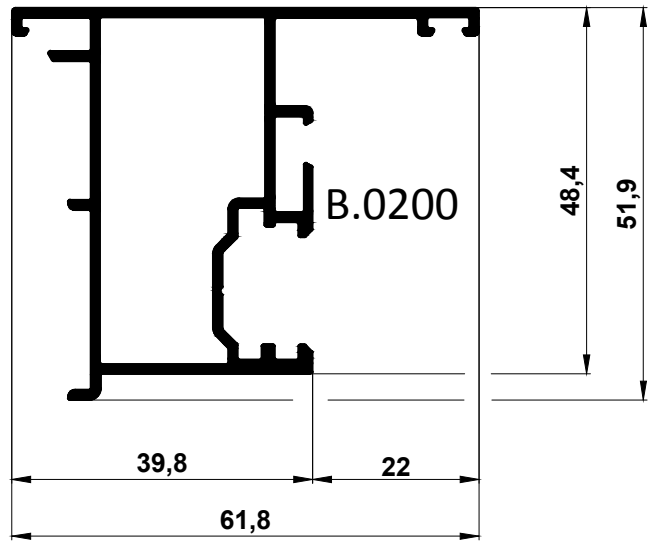

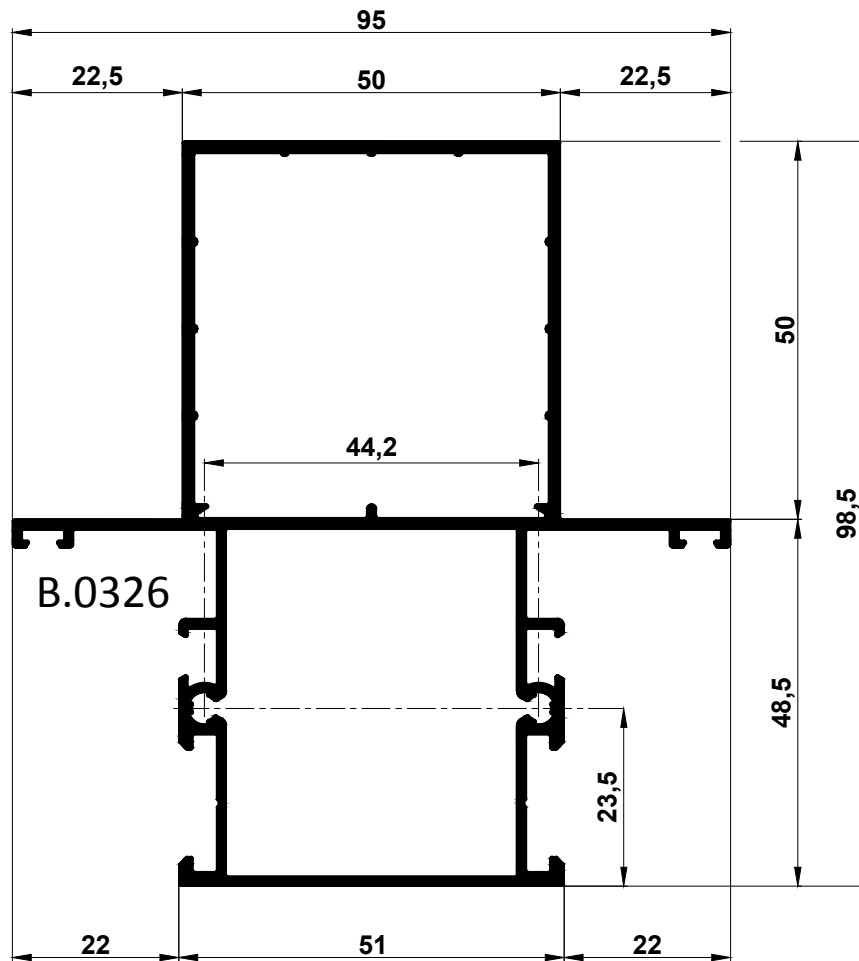
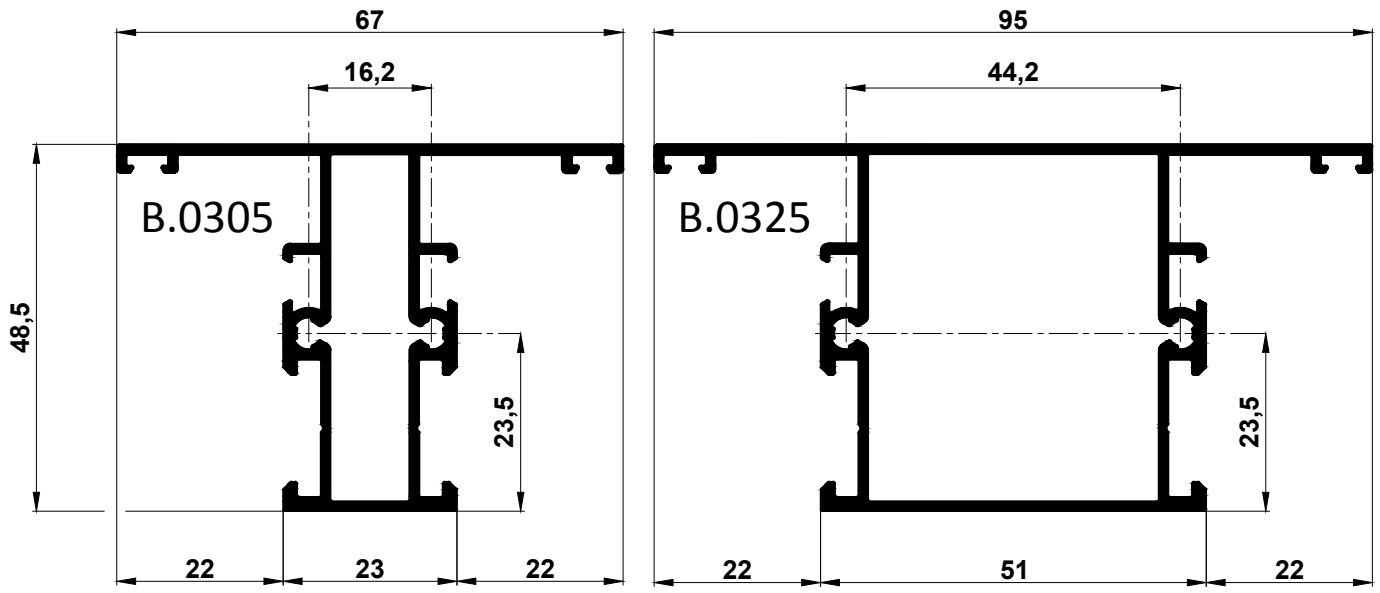

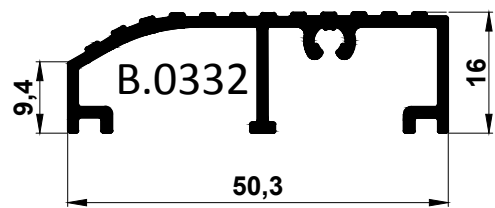
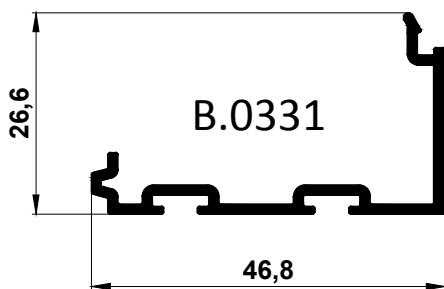
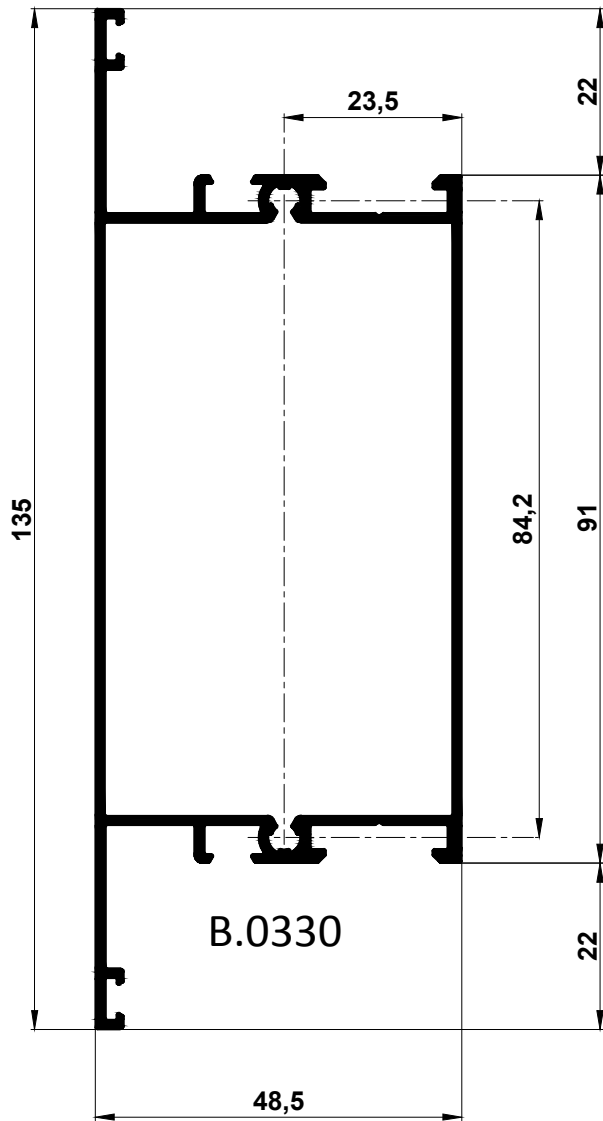

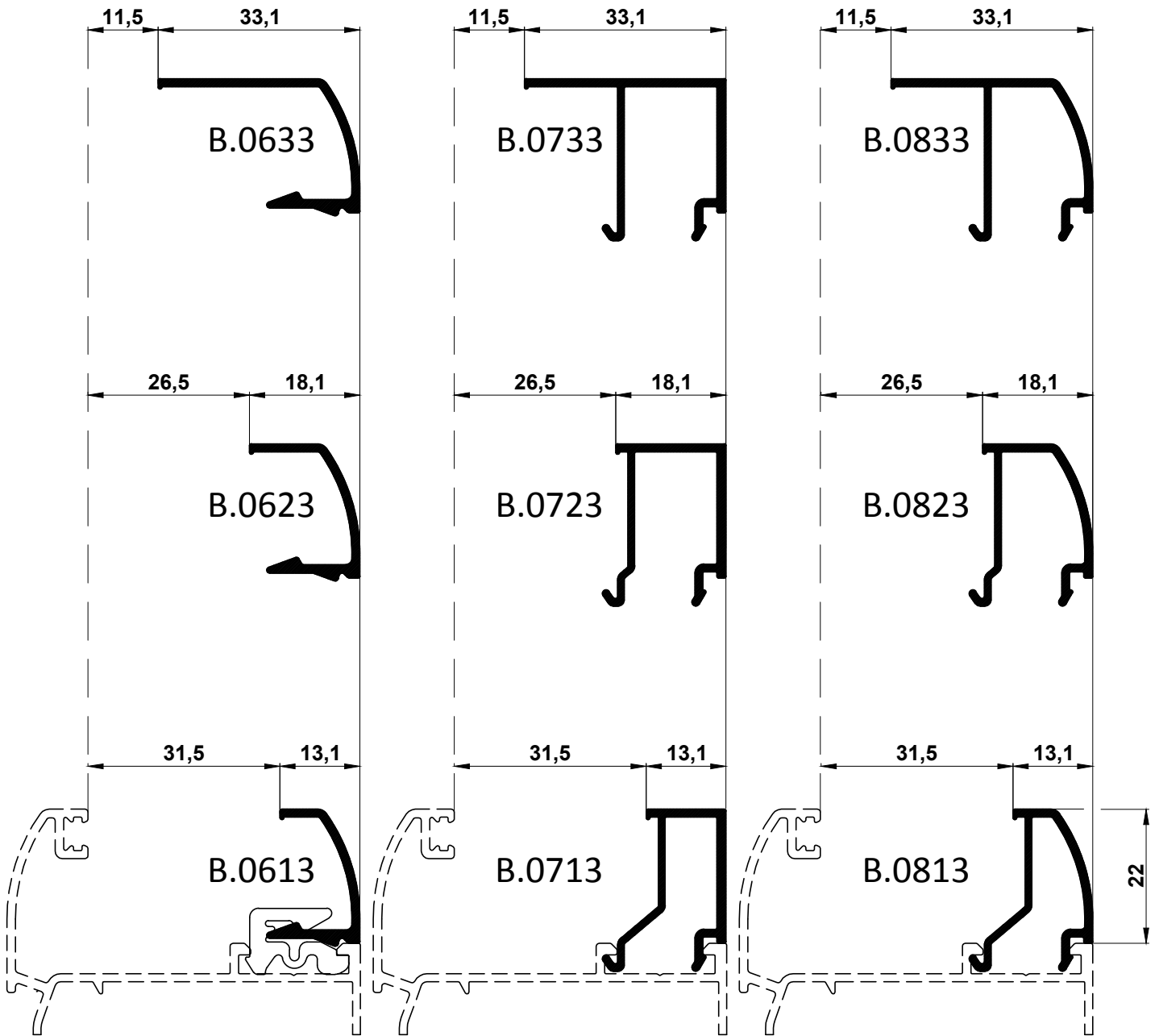

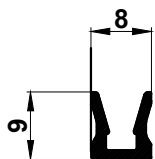

X.0010

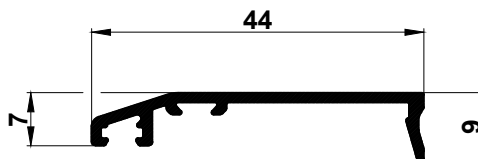

X.0040

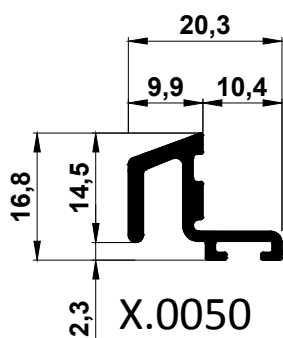

X.0050

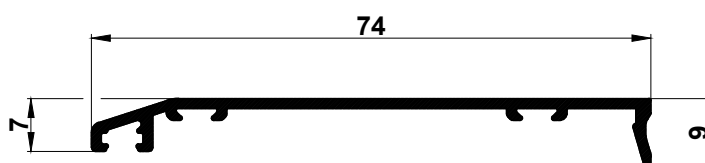

X.0070

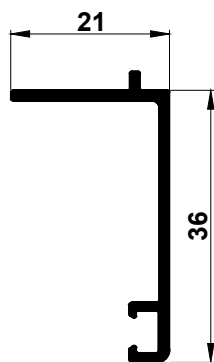

X.0060

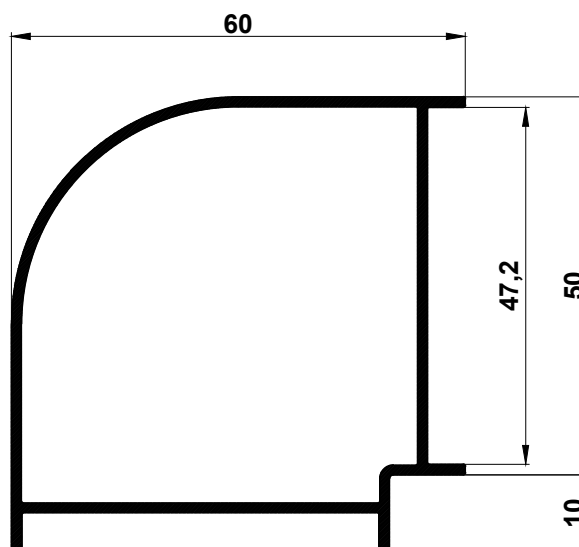

X.0190



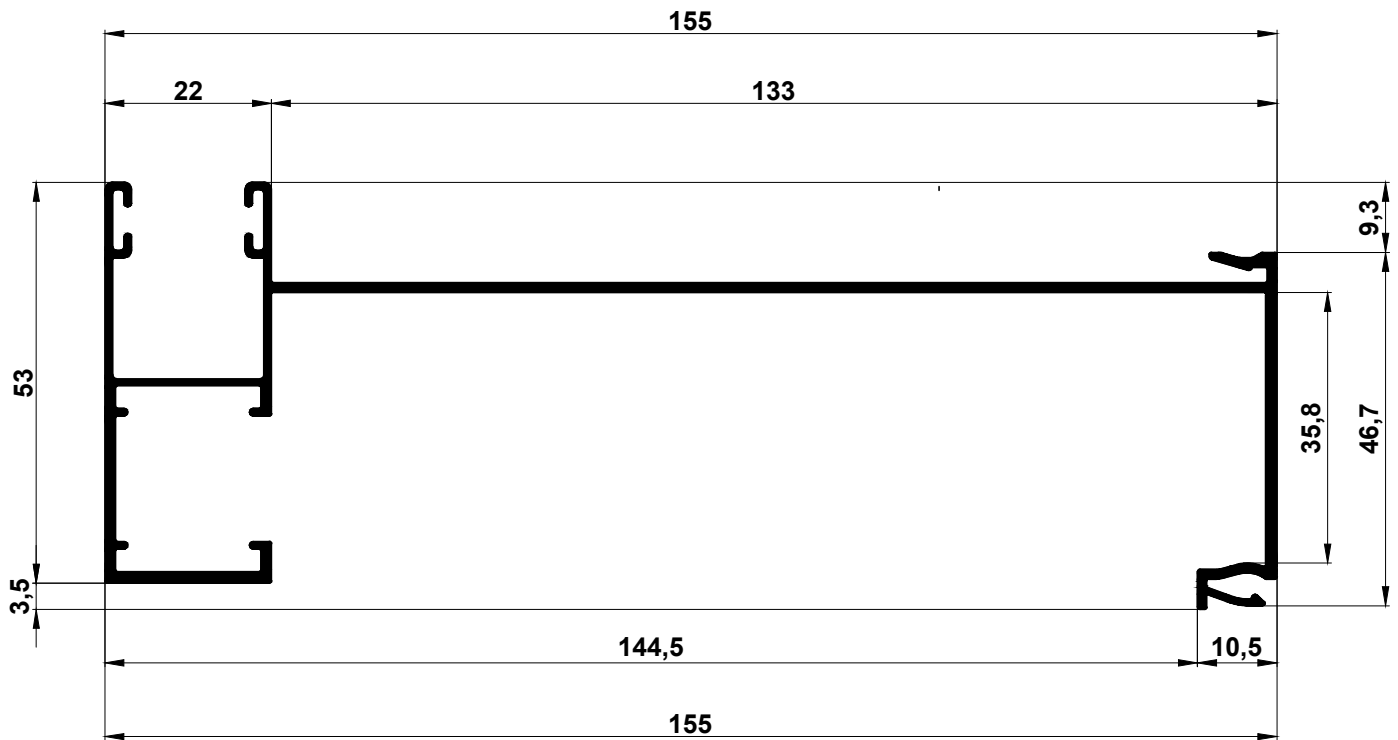
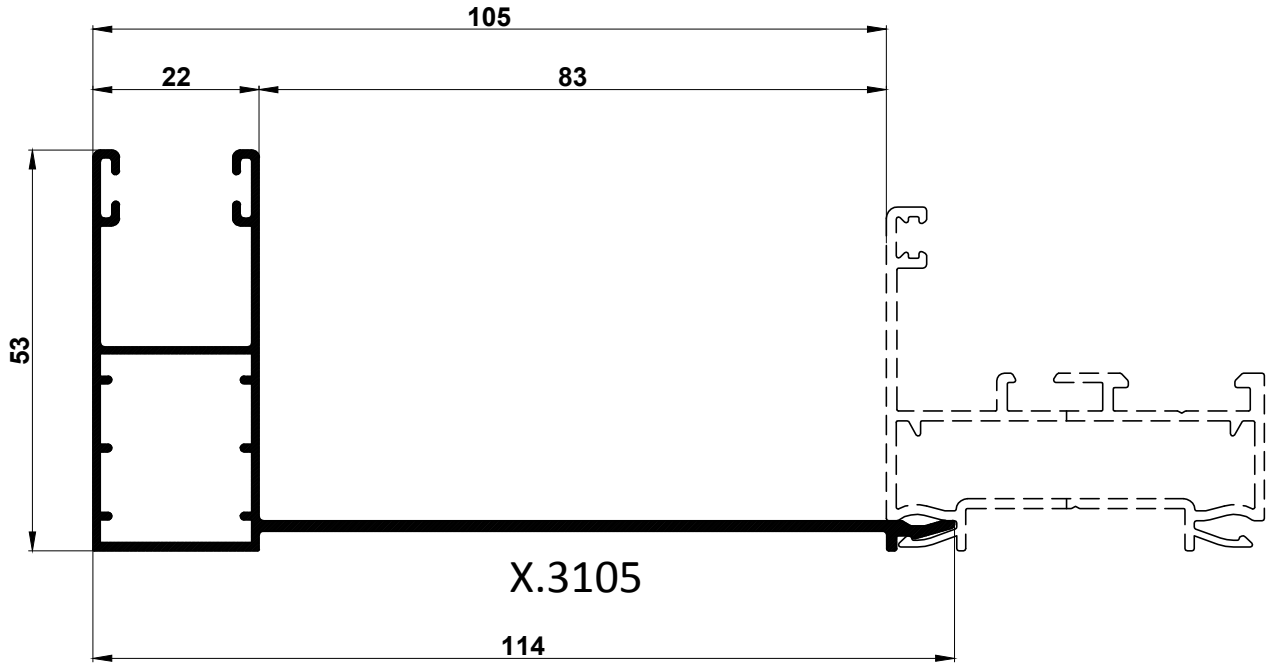

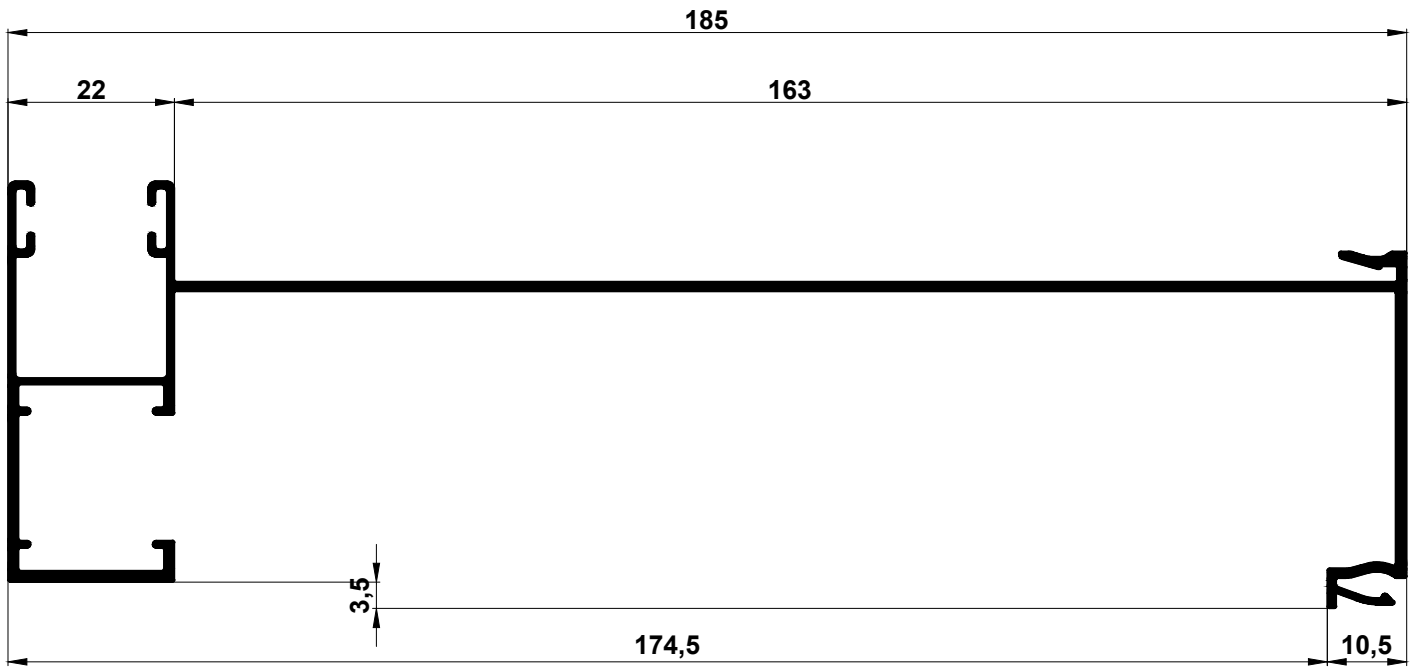



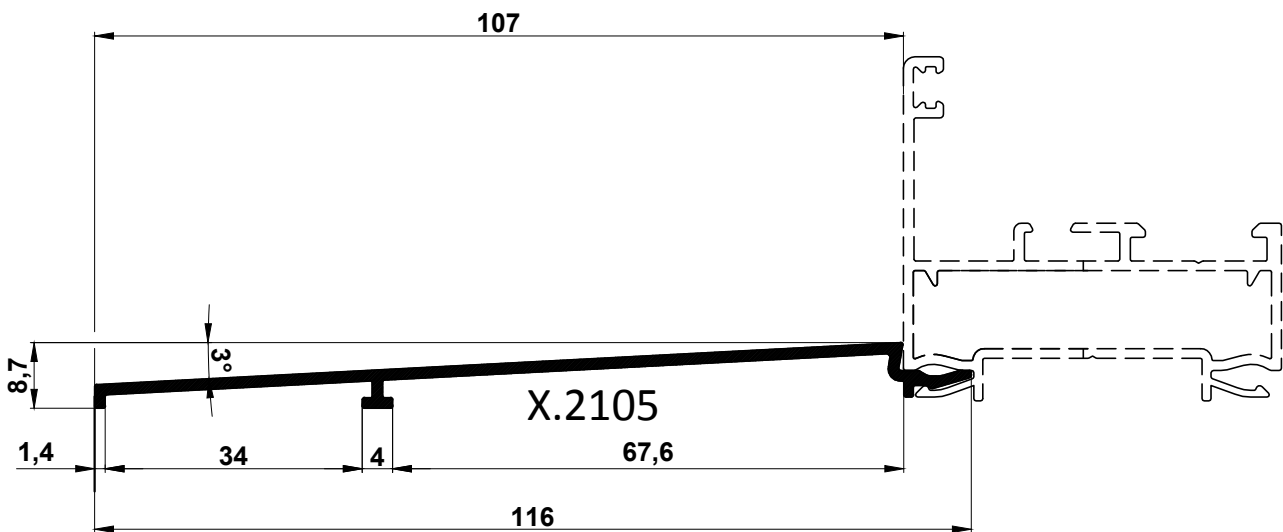





XP2.185

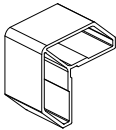
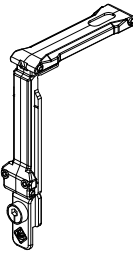
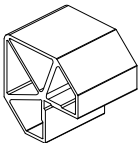

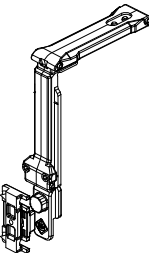
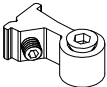
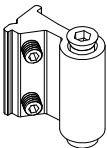
X.2105

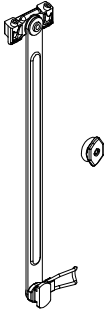

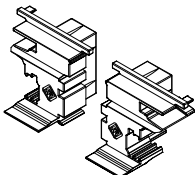
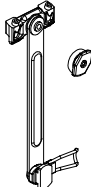
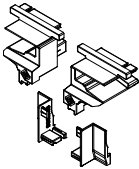

# NOMENCLATURE ACCESSORIES





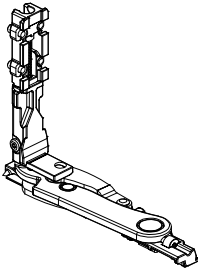
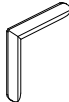

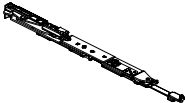
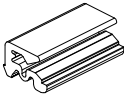
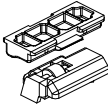
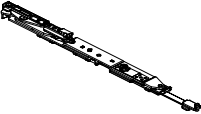
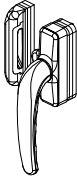
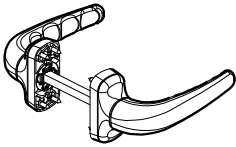
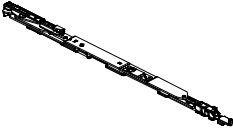
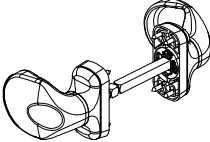
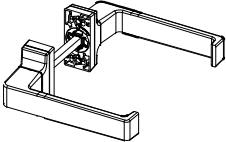
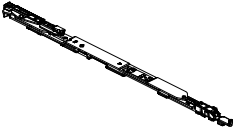



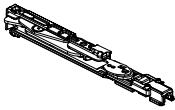

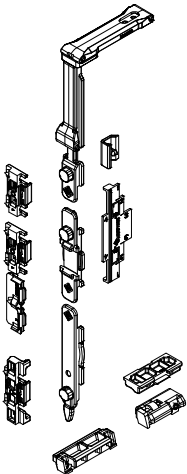
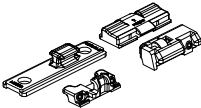
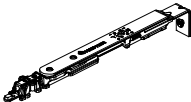
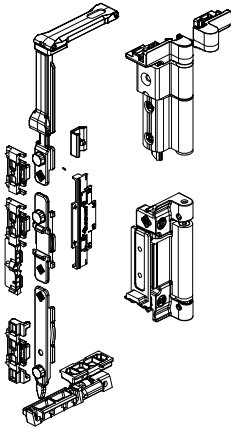
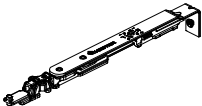
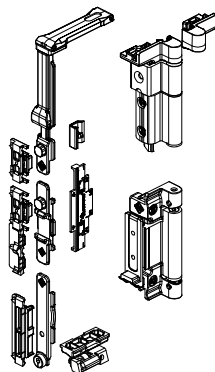
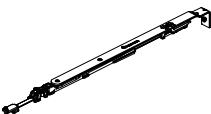
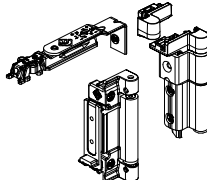
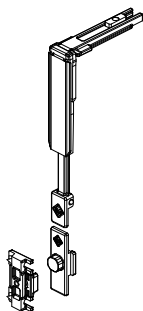
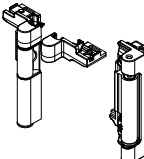
	REF.	DESCRIPTION		REF.	DESCRIPTION
	0280	Supplément Equerre 13,5 (de 10,3 a 23,8)		1252.12	Renvoi d'angle
	0281	Supplément Equerre (de 10,3 a 42,3)			
	0311	Equerre dormant		1252.16	Renvoi d'angle avec point de fermeture supplémentaire
	0475.10	Bloc d'assemblage (10,4)			
	0475.11	Bloc d'assemblage (38,4)		1500.5	Cliquet en zamak
	1115.1	Bras liiteur d'ouverture vantail hauteur 600 à 1600		2010.2	Tringle
				PP010	Embout battement central
	1115.2	Bras liiteur d'ouverture vantail hauteur 290 à 800		PP011	Embout battement central réduit
				2129.4	Cache cylindre Italia
				2133	Verin de pose

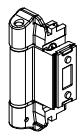
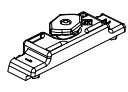
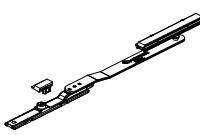
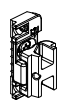
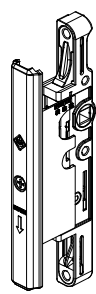



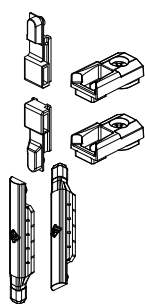

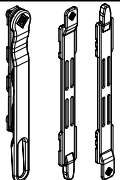

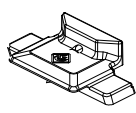
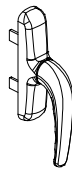
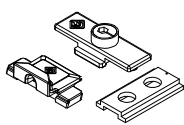
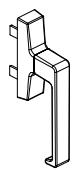
# NOMENCLATURE ACCESSORIES

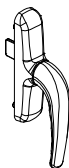
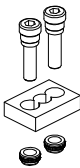
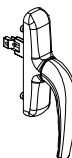
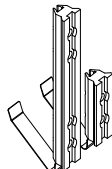
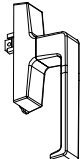

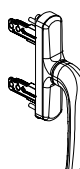
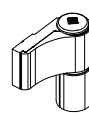
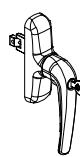
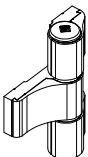
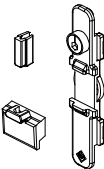

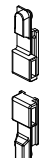
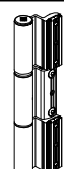
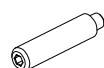

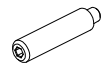
	REF.	DESCRIPTION		REF.	DESCRIPTION
	2145	Busette d'évacuation		3302	Paumelle inf invisible s/d
	2194.1	Equerre d'alignement			
	2190.9	Equerre d'alignement ouvrant		3302.20	Bras court réglable pour paumelle invisible vantail semi fixe s/d
	2210	Clip parclose			
	2432.1	Point support vantail		3302L.20	Bras court réglable pour paumelle invisible vantail semi fixe s/d manœuvre Logique
	3042	Poignée à olive			
	3060	Double bequille Comfort		3302.21	Bras long réglable pour paumelle invisible vantail semi fixe s/d
	3064.1	Poignée Spin			
	3065	Double bequille Italia		3302L.21	Bras long réglable pour paumelle invisible vantail semi fixe s/d manœuvre Logique
	3075	Bequille Comfort Mini			

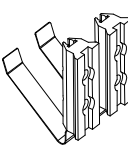
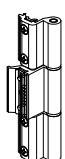
REF.	DESCRIPTION	REF.	DESCRIPTION
	3302.71 Paumelle invisible s/d		3400F.32 Point fermeture supplémentaire
	3320F.1 Kit de fermeture Ween		3400F.35 Fermeture horizontale Ween
	3400.20 Bras ob Ween (vantail 370-450)		3420F.1 Kit base Ween oscillo battent
	3400.21 Bras ob Ween (vantail 451-650)		3420LF.1 Kit ob Ween - Manoeuvre Logique
	3400.22 Bras ob Ween (vantail 651-1700)		3420.23 Kit paumelle ob Ween vantail semi fixe
	3400F.31 Point fermeture supplémentaire		3420.24 Kit paumelle ob Ween

REF.	DESCRIPTION	REF.	DESCRIPTION
	3420.71 Paumelle à peigne		4220.1 Clip blouque vantail
	3520.30 Bras supplémentaire ob Ween (vantail 1200-1700)		4226.1 Crochet fermeture supplémentaire
	3626.2 Mécanisme manoeuvre bidirectionnel		4501.50 Verrou a levier
			4504.50 Verrou a levier
	4011.20 Verrou semi fixe fenetre		4032.63 Kit cremone 1 vantail
	4032.20 Embout de tringle		4515.1 Verrou a levier bi-directionnel
	4206 Double gache cremone		4550.1 Verrou a levier
	4207.4 Pivot fermeture supplémentaire		6004 Crémone Comfort
	4207.21 Point fermeture additionelle		6008 Crémone Italia

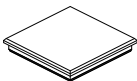
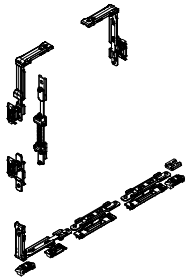

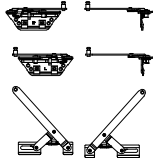
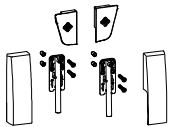
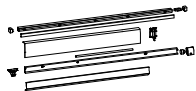
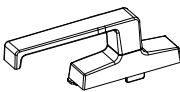



	REF.	DESCRIPTION		REF.	DESCRIPTION
	6010.21	Crémone Comfort		8010.7	Epaisseur 10mm et vis
	6011.10	Crémone Comfort ob		8010.10	Pièces fixation paumelle 8011.11
	6018	Crémone italia p/ oscillo battent		8010.16	Plaques fixation paumelles
	6028.3	Crémone Comfort Plus		8011	Paumelles Dinamika deux corps
	6036.20	Crémone avec clé s/d ob Logica		8011.11	Paumelles Dinamika trois corps
	6111.1	Bloc de jonction		8060	Paumelle Slim Rapid à deux corps
	6401.1	Renvoi de tringle		8060.6	Paumelle Slim Rapid à trois corps
	6420E.25	Pivot de jonction (L=25mm)		8060.20	Réglage vert paumelle Silm Rapid
	6420E.31	Pivot de jonction (L=31mm)		9211.3	Paumelle Top Rapid à deux corps
	8000.9	Pièces fixation paumelle 8011		9211.6	Paumelle Top Rapid à trois corps

REF.	DESCRIPTION	REF.	DESCRIPTION
	TC952.2 Bloc outil		2014 Poinçonneuse
	2313 Bouchon 50 x 50		
	3920.2 Kit coulissant parallele semi-automatique		
	3900.200D Paire chariots pour coulissant parallele droite		
	3915 Kit compas coulissant parallele kit compas universels		
	3910.12 Kit cover pour chariots et compas		
	3940.13 Kit profiles L= 1281- 1680 mm		
	6018.41 Cremone ITALIA anti f.m.sup. pour Coulissant parallele		

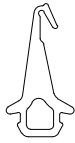

## NOMENCLATURE JOINTS



REF.	DESCRIPTION	REF.	DESCRIPTION
 IYS 27-10	Joint central	 SY4 - 11	Joint vitrage exterieur 1mm
 SY3-247	Joint de battement	 CF - 4113	Joint vitrage 2mm
 AG1503A	Joint brosse 6,9x8mm avec pinne centrale	 CF - 4114	Joint vitrage 3mm

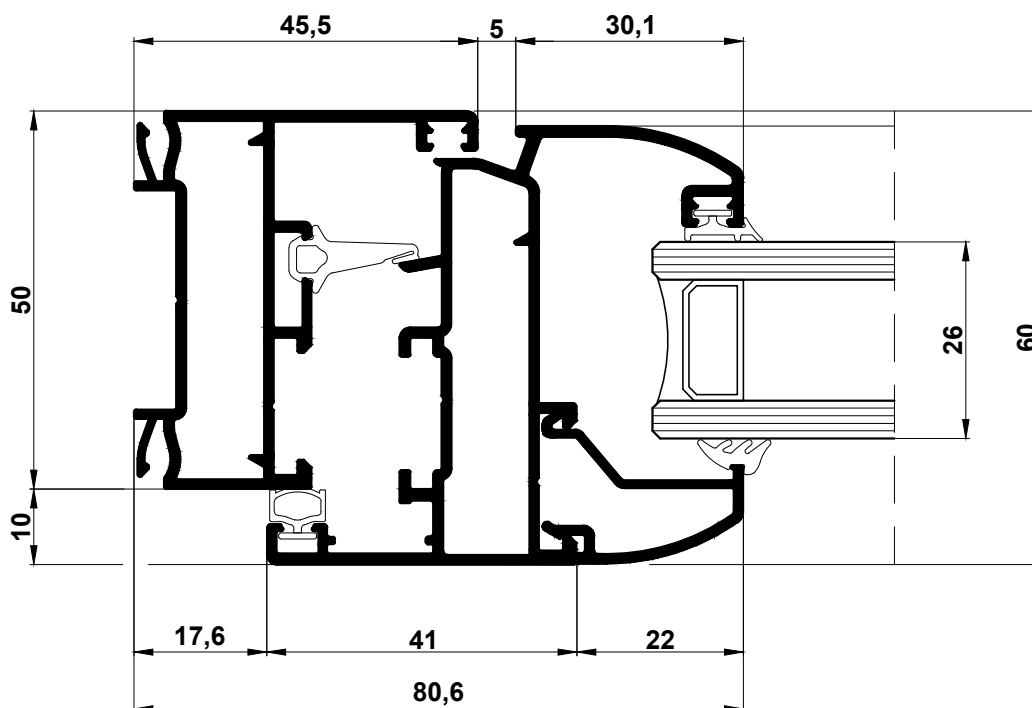
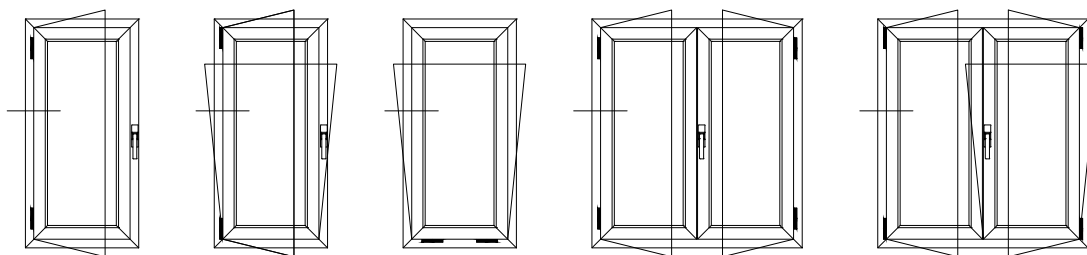

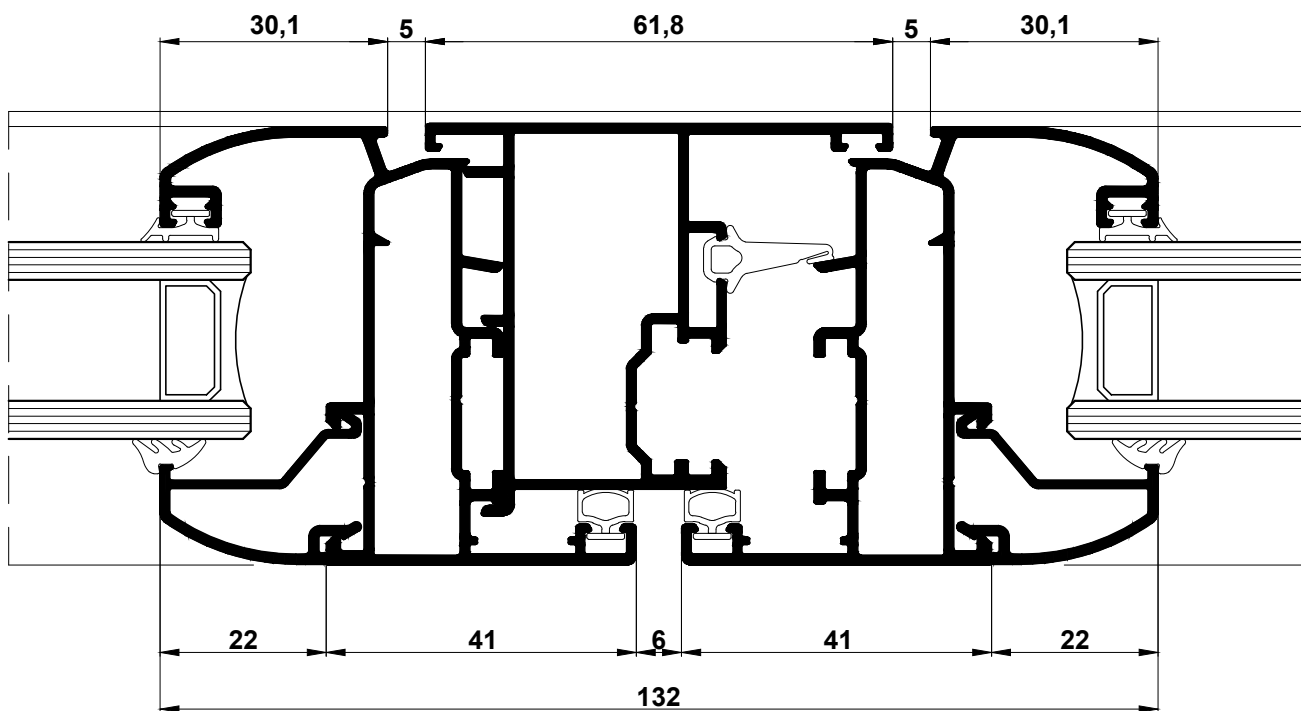
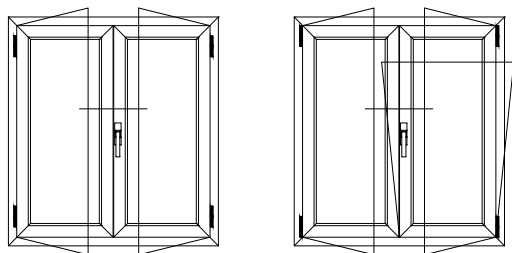

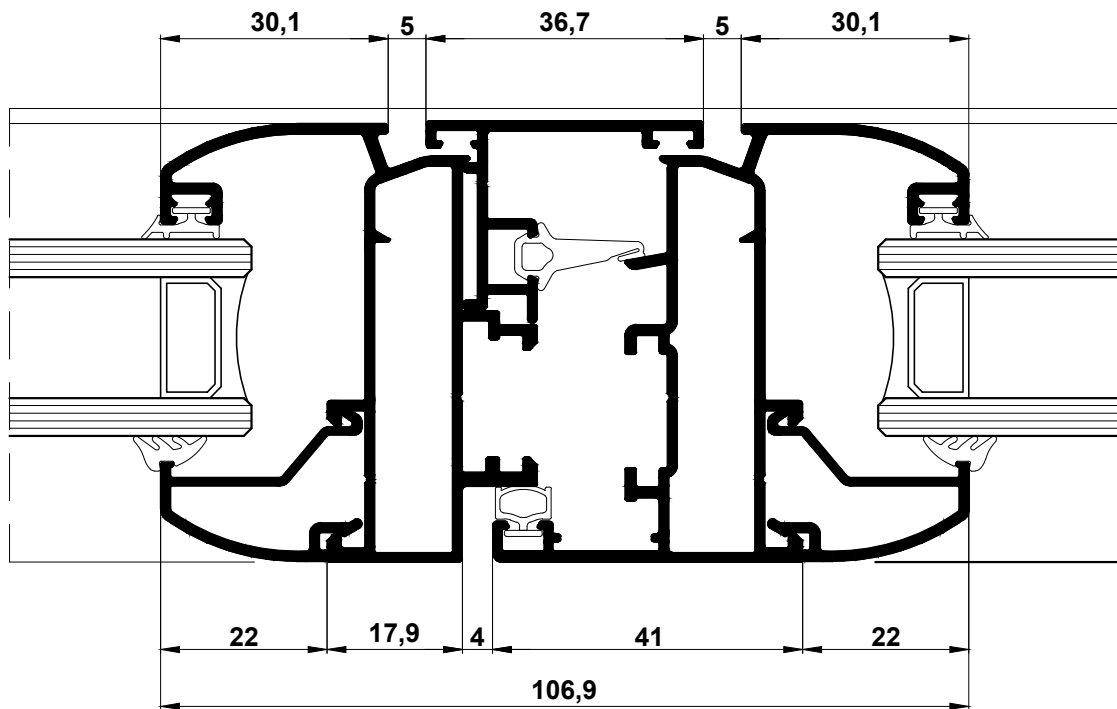
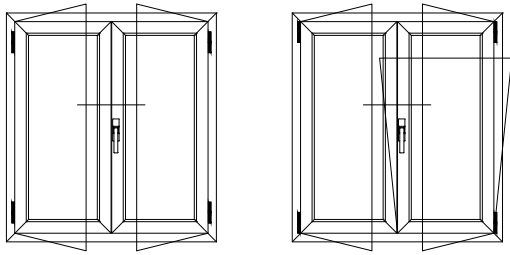

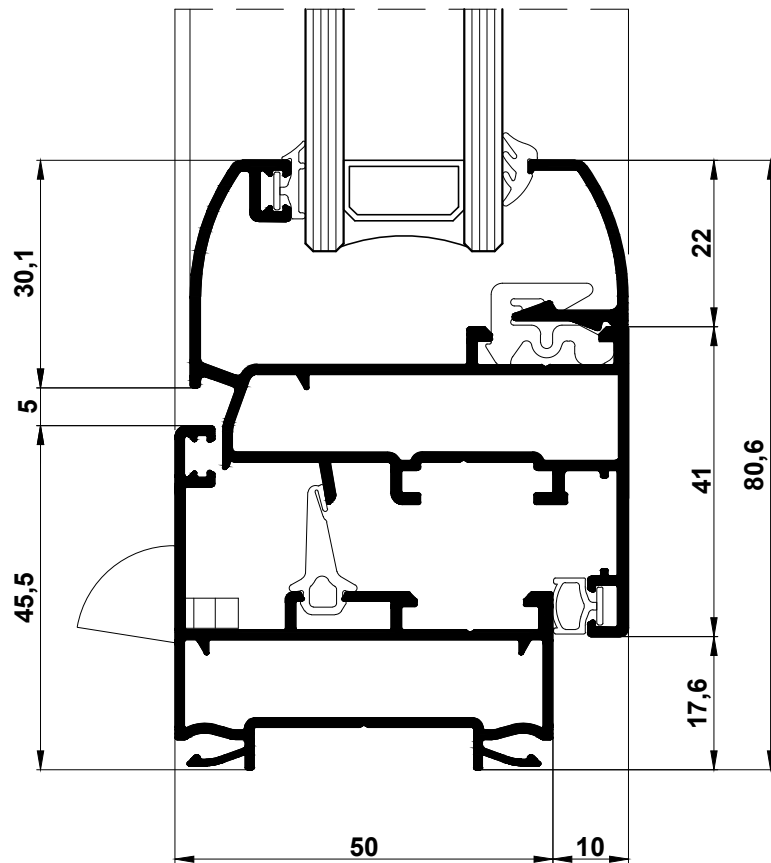
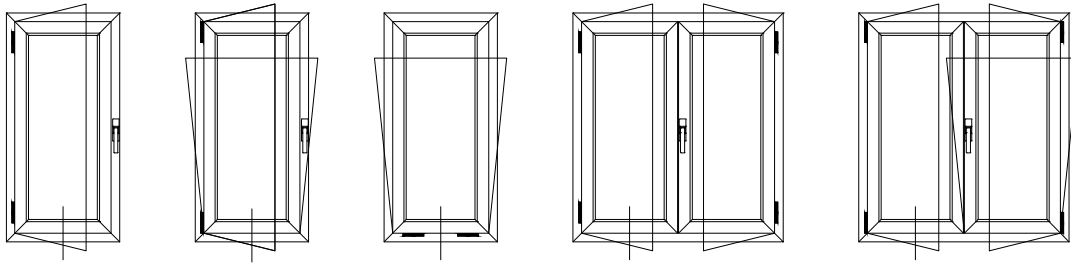

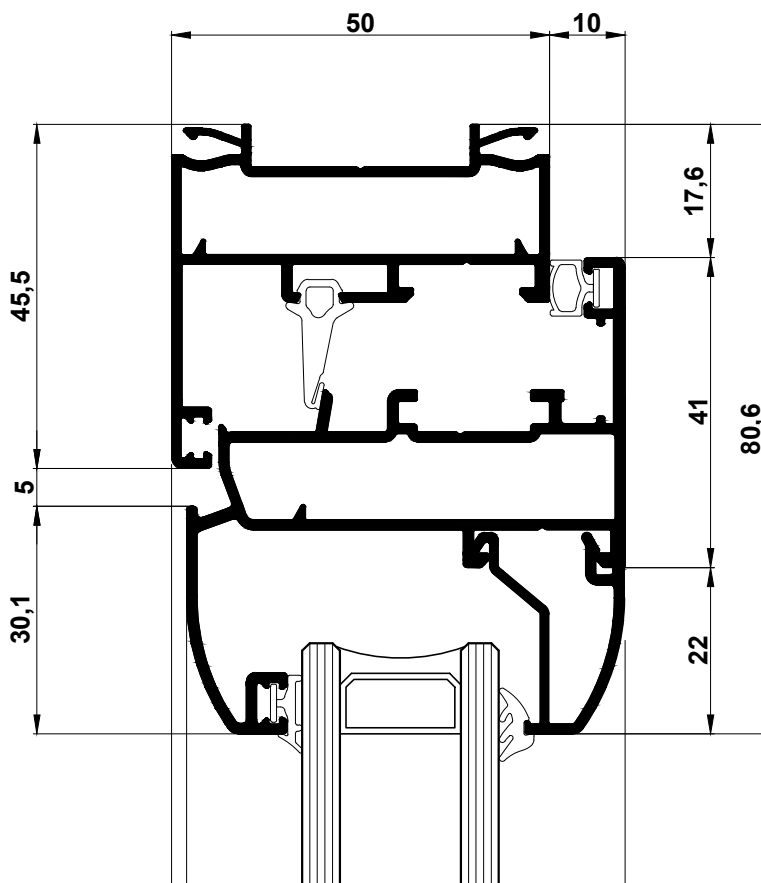
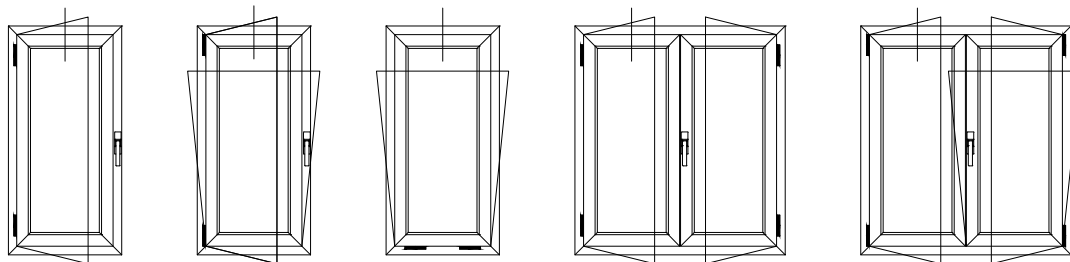

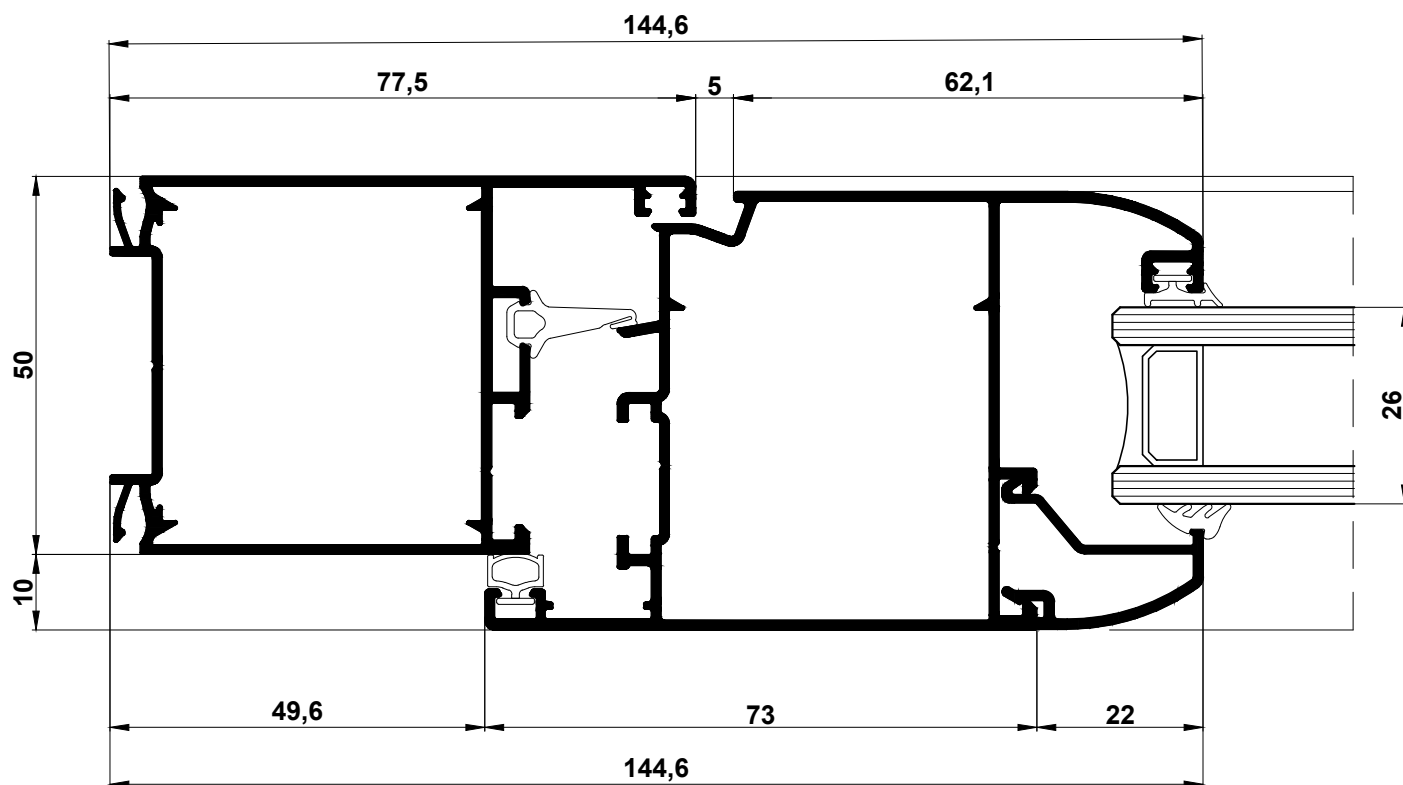
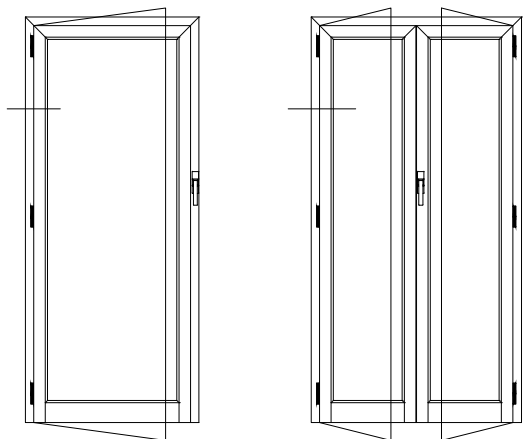

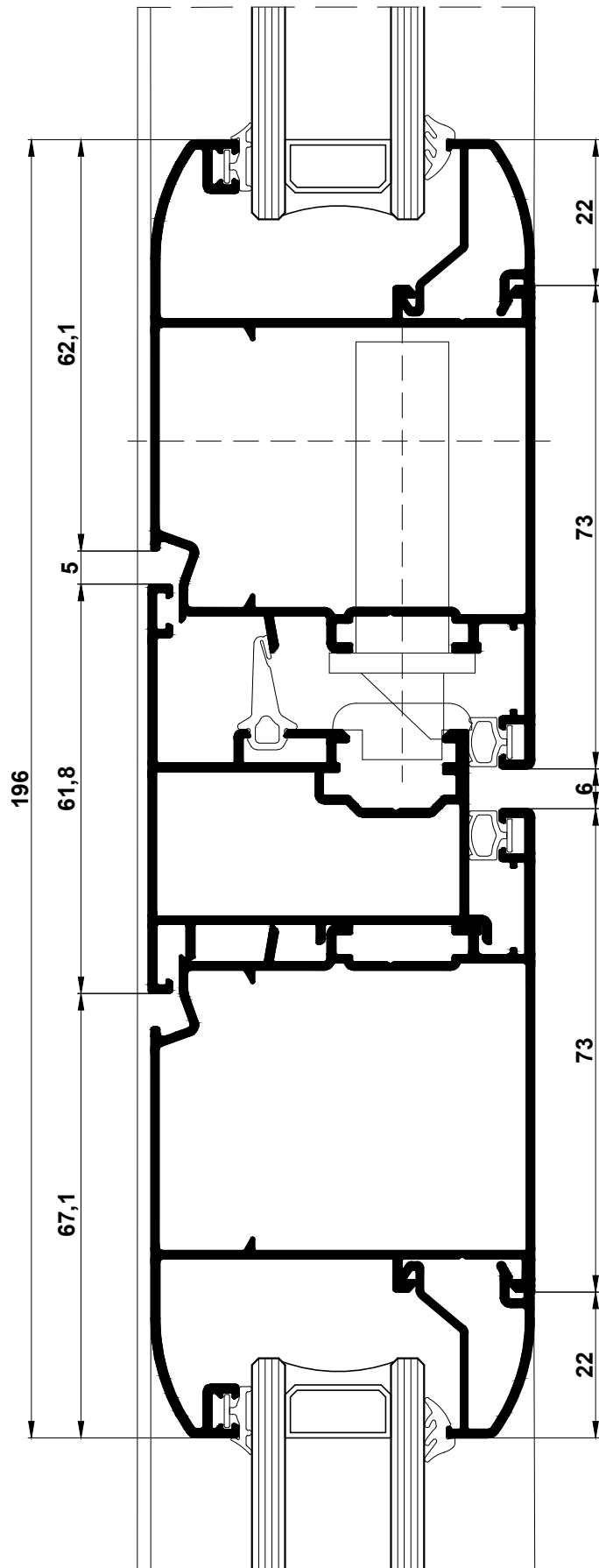
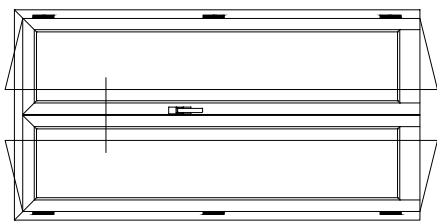



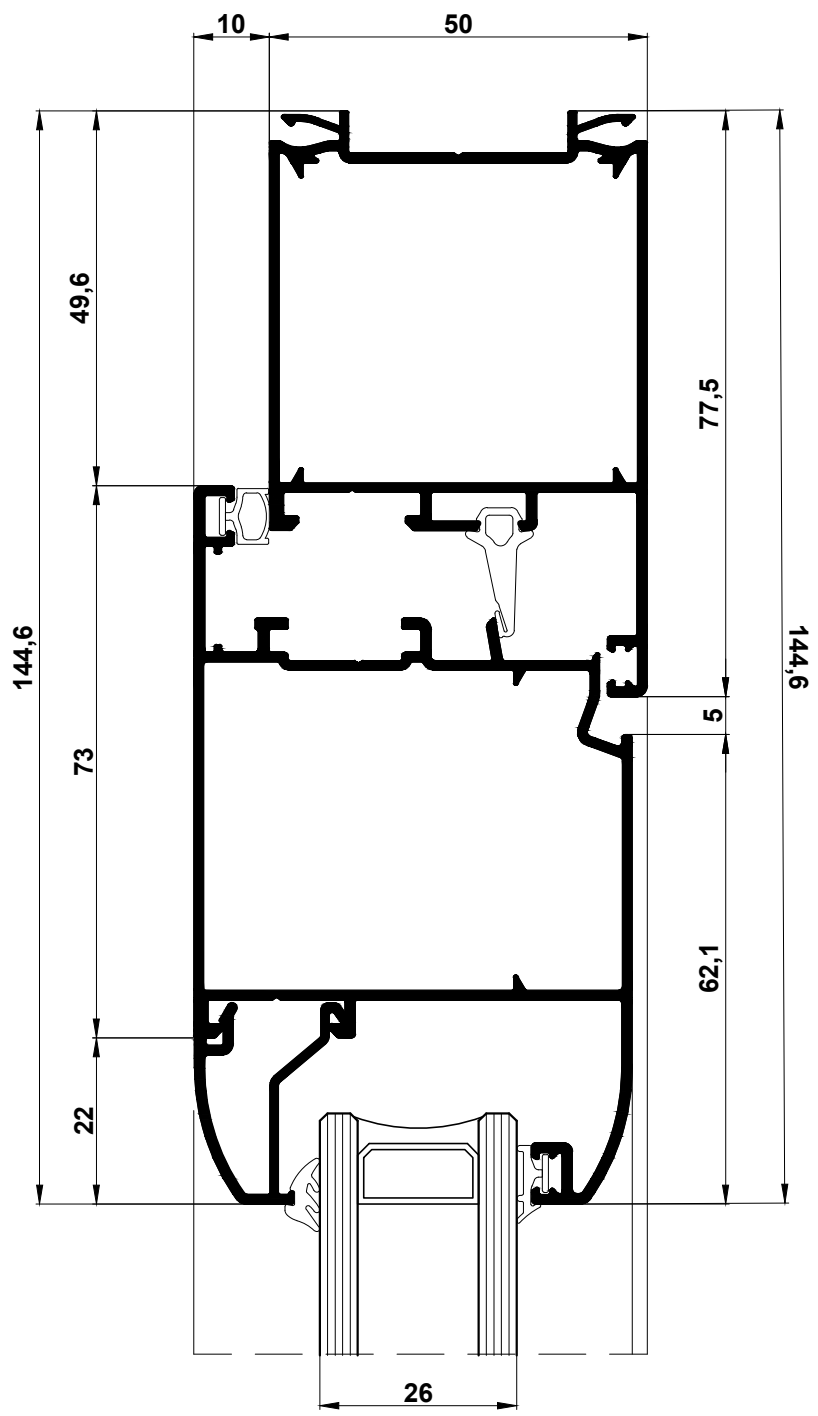
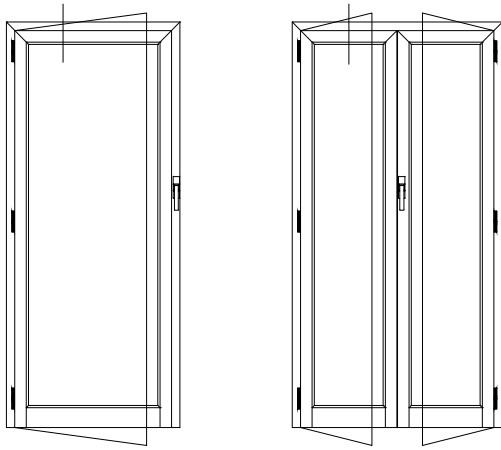

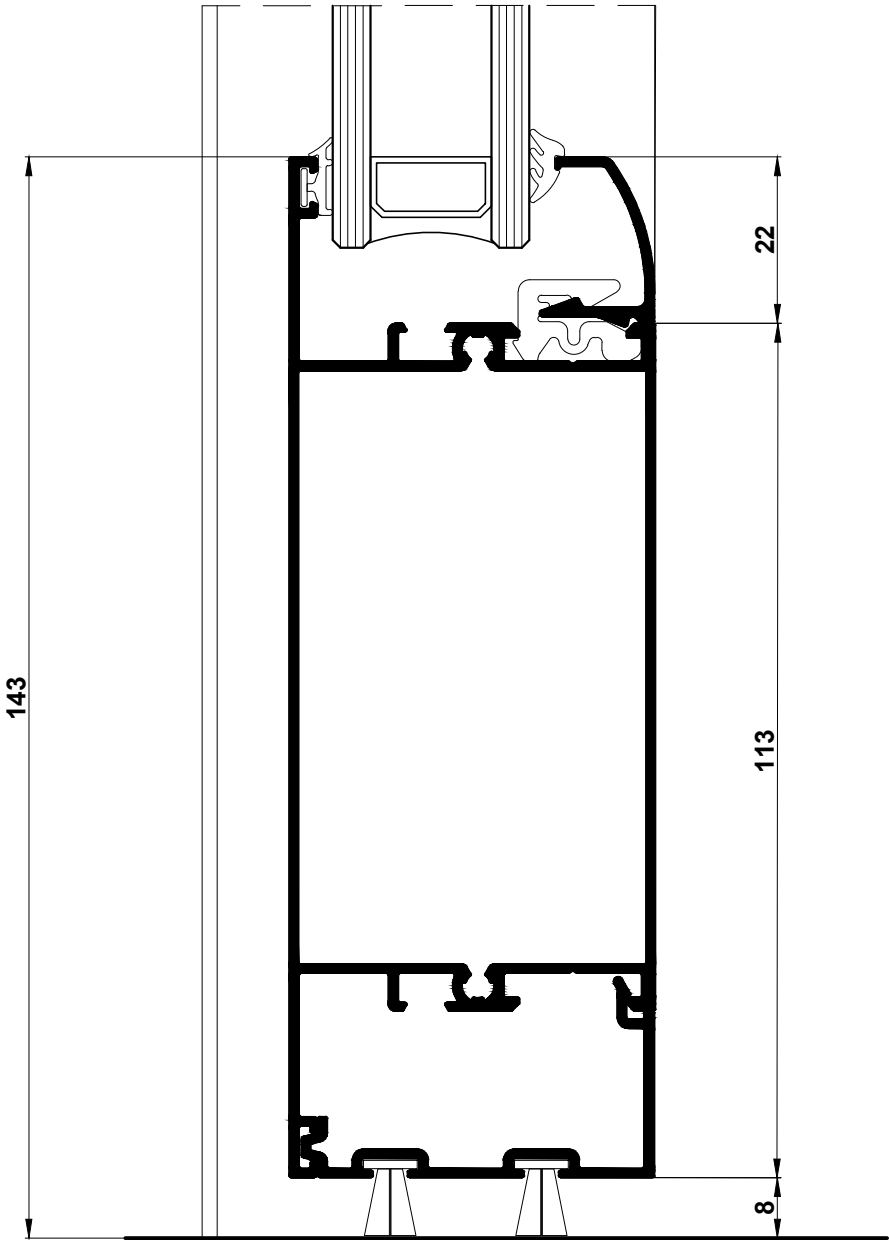
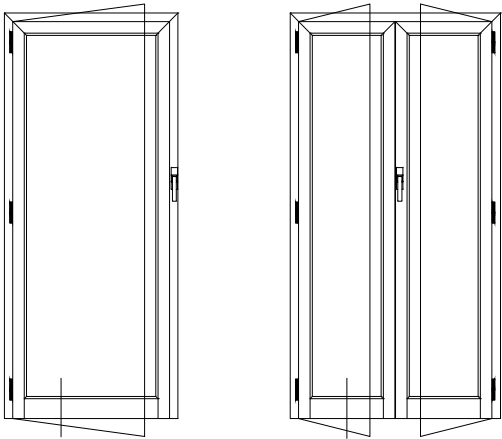

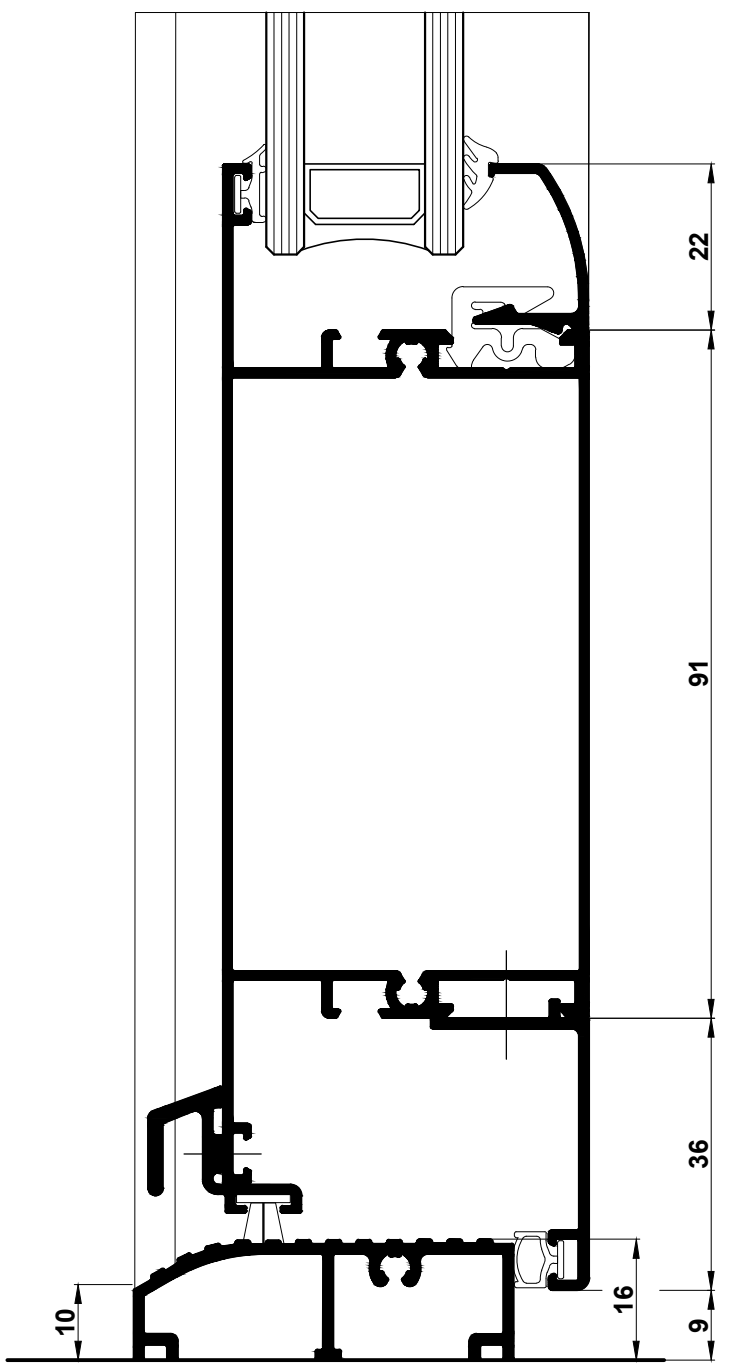
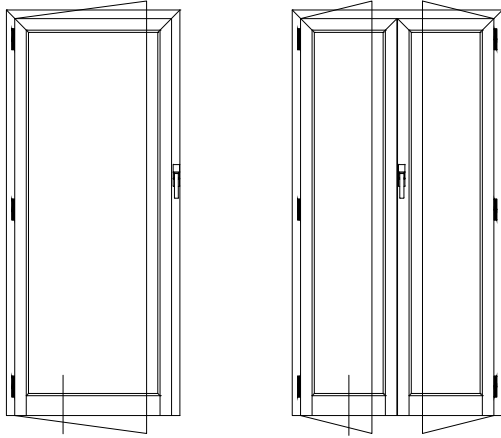

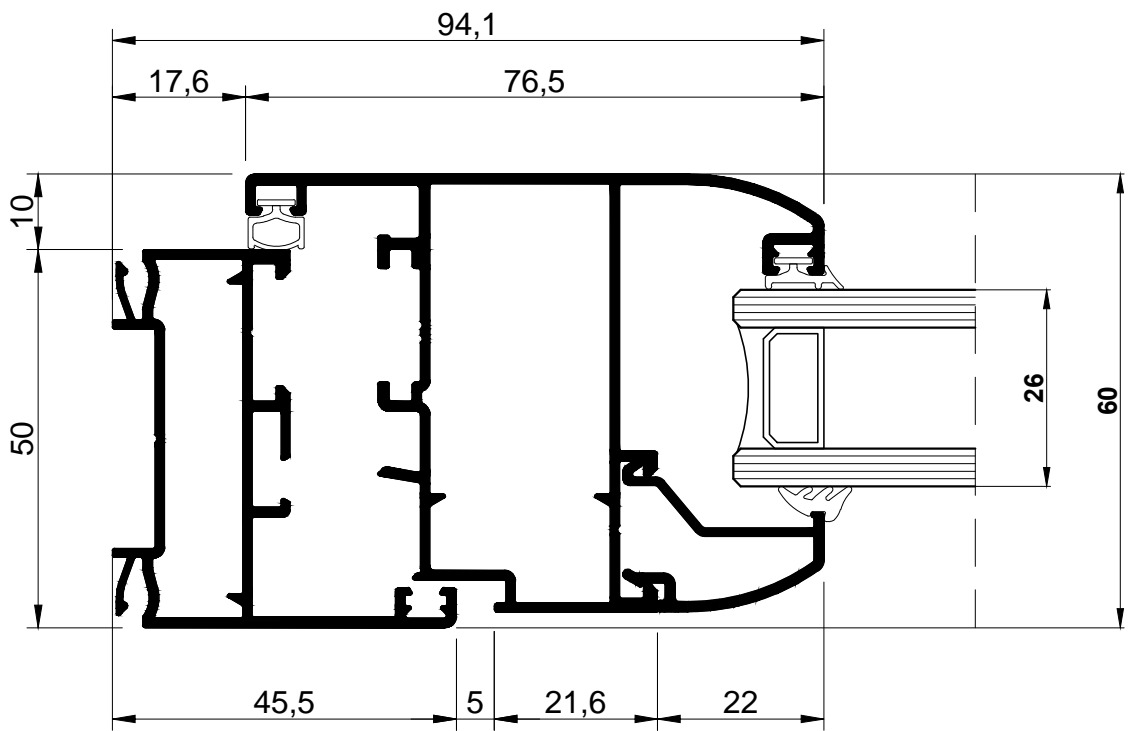
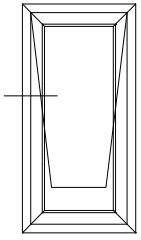

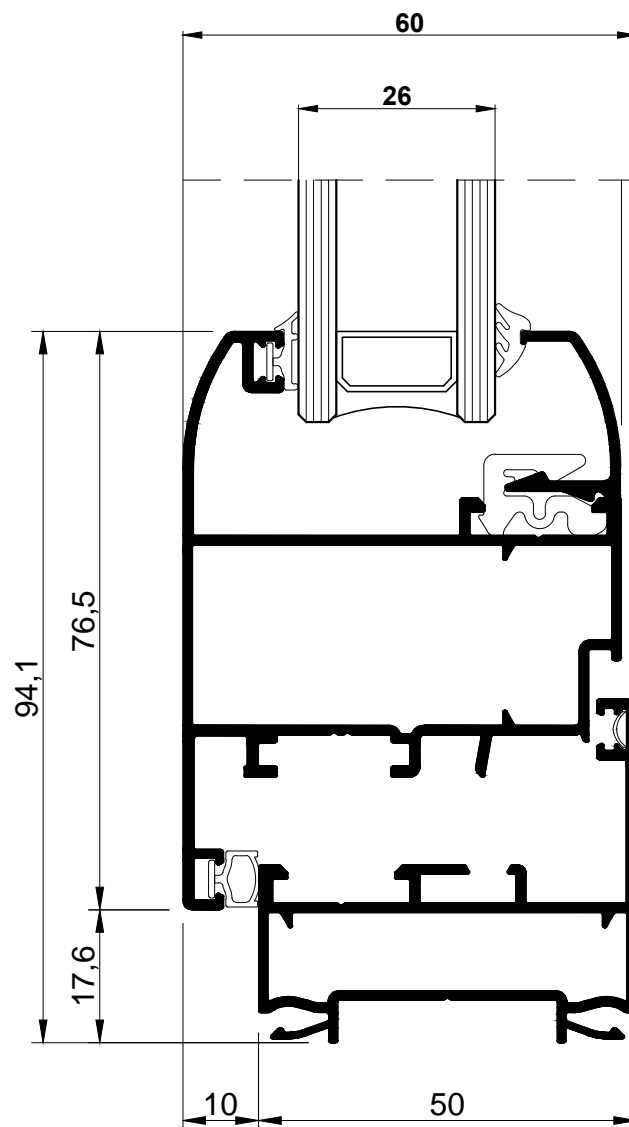
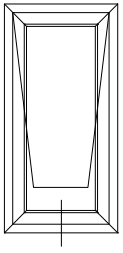

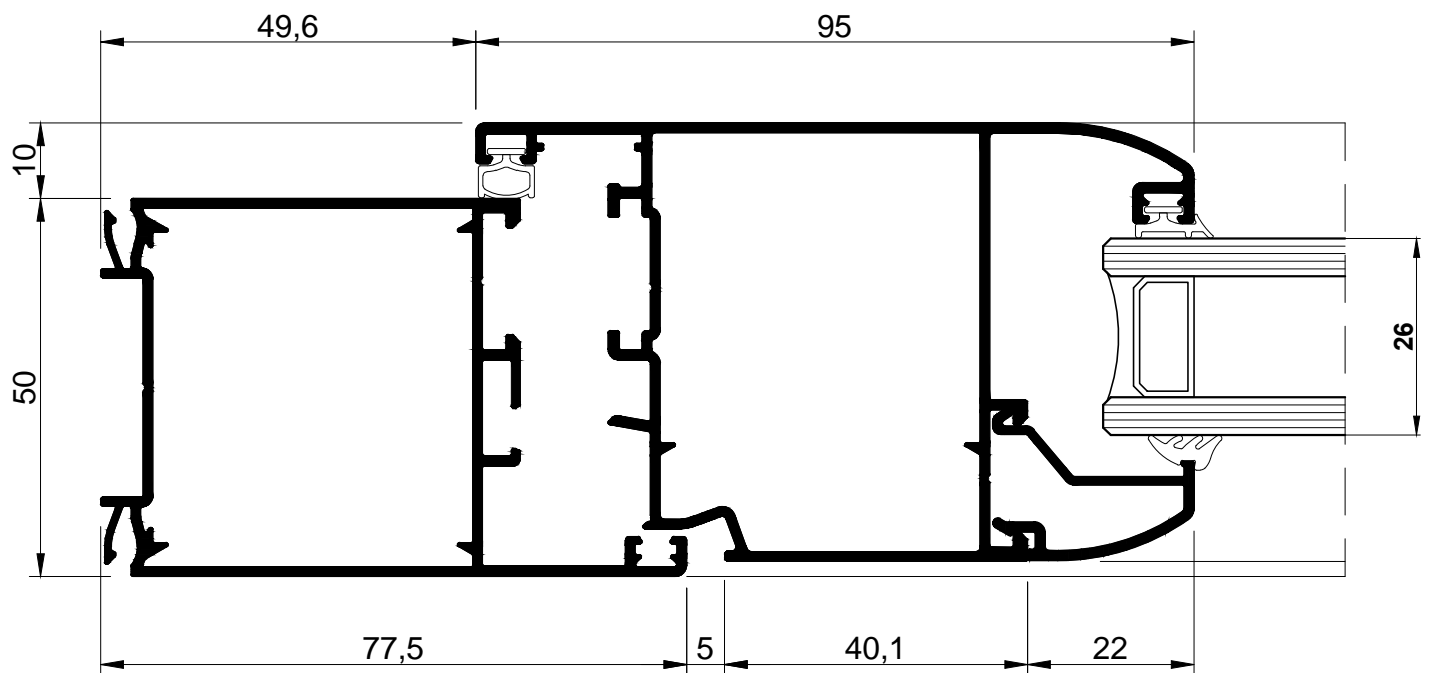
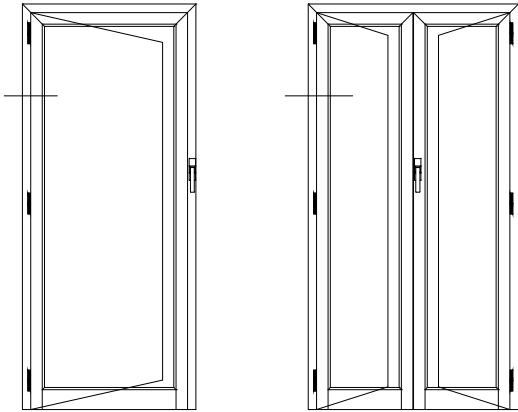

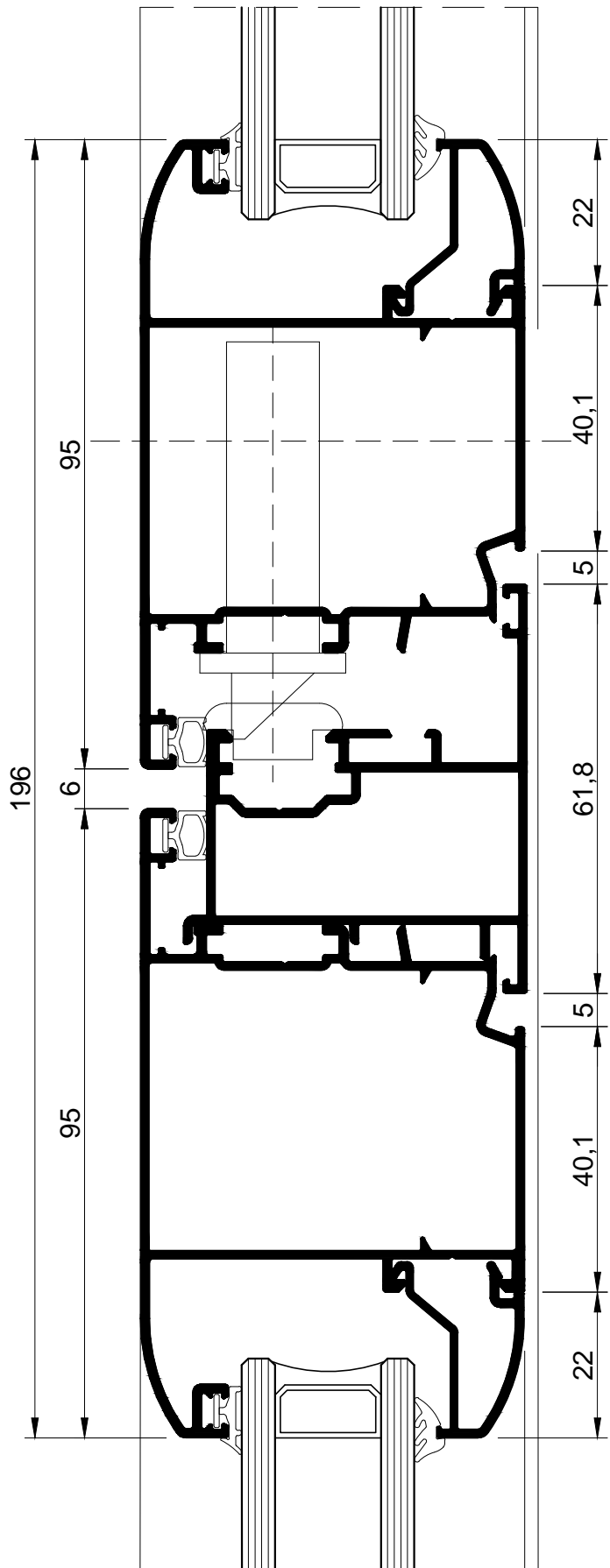
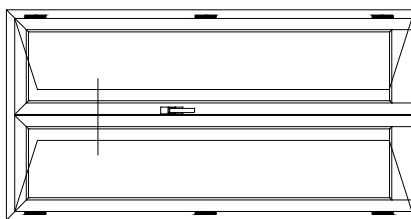

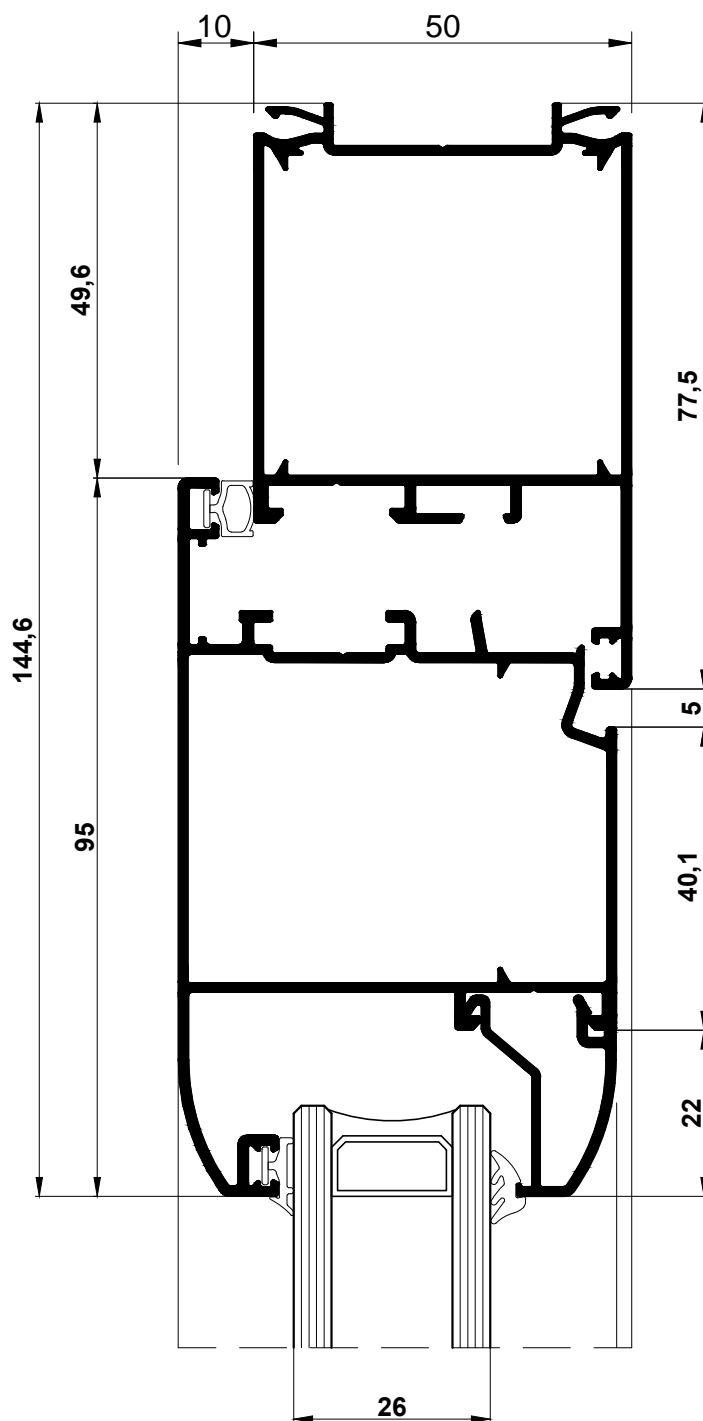
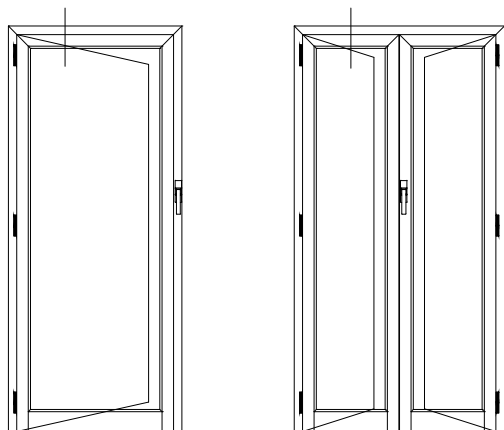



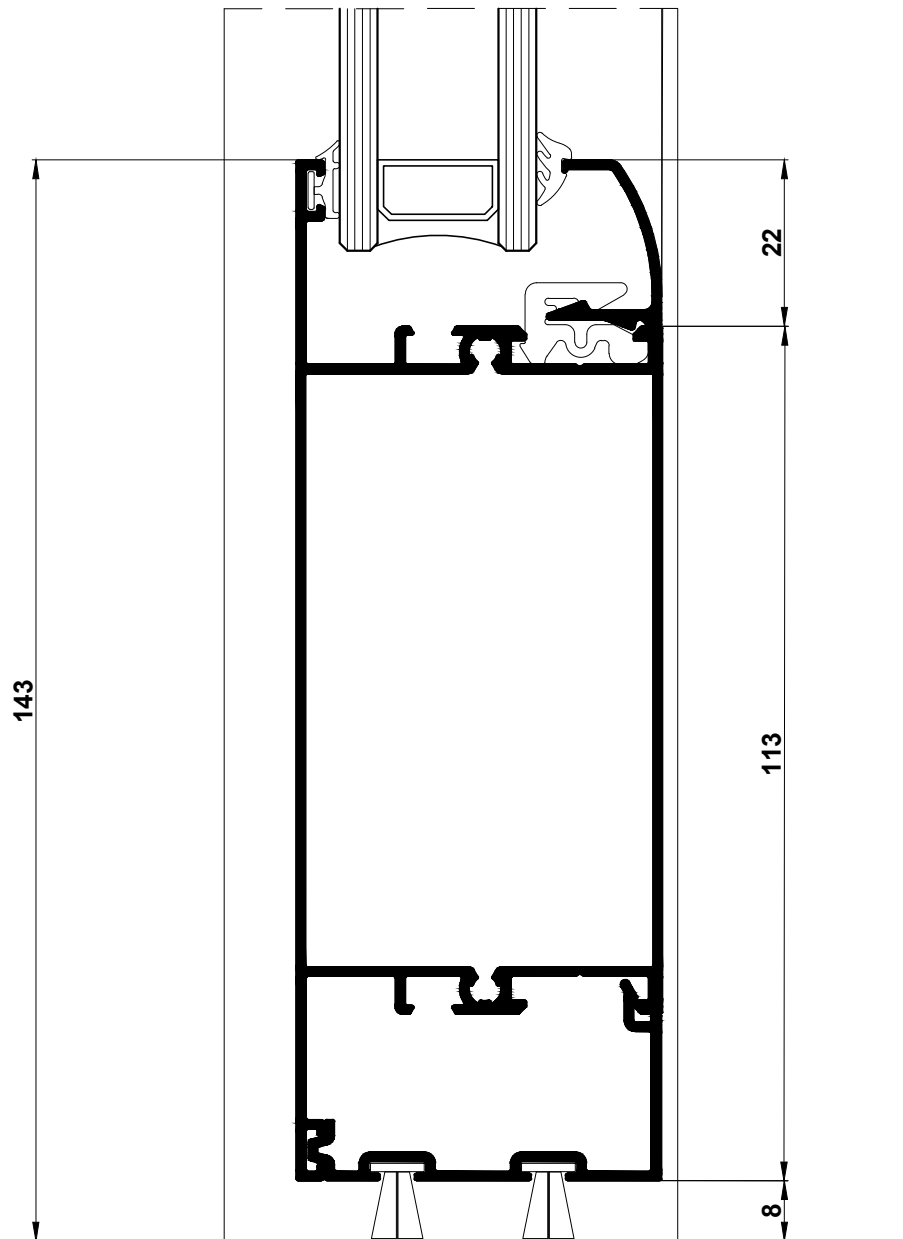
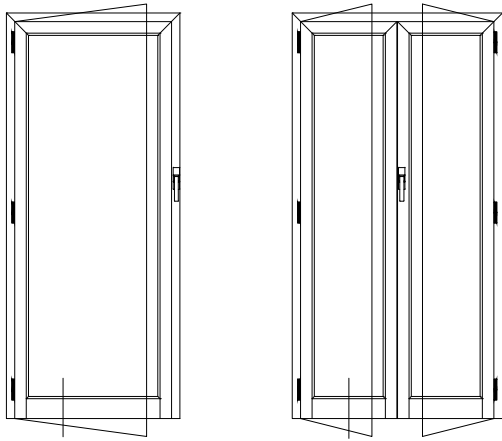

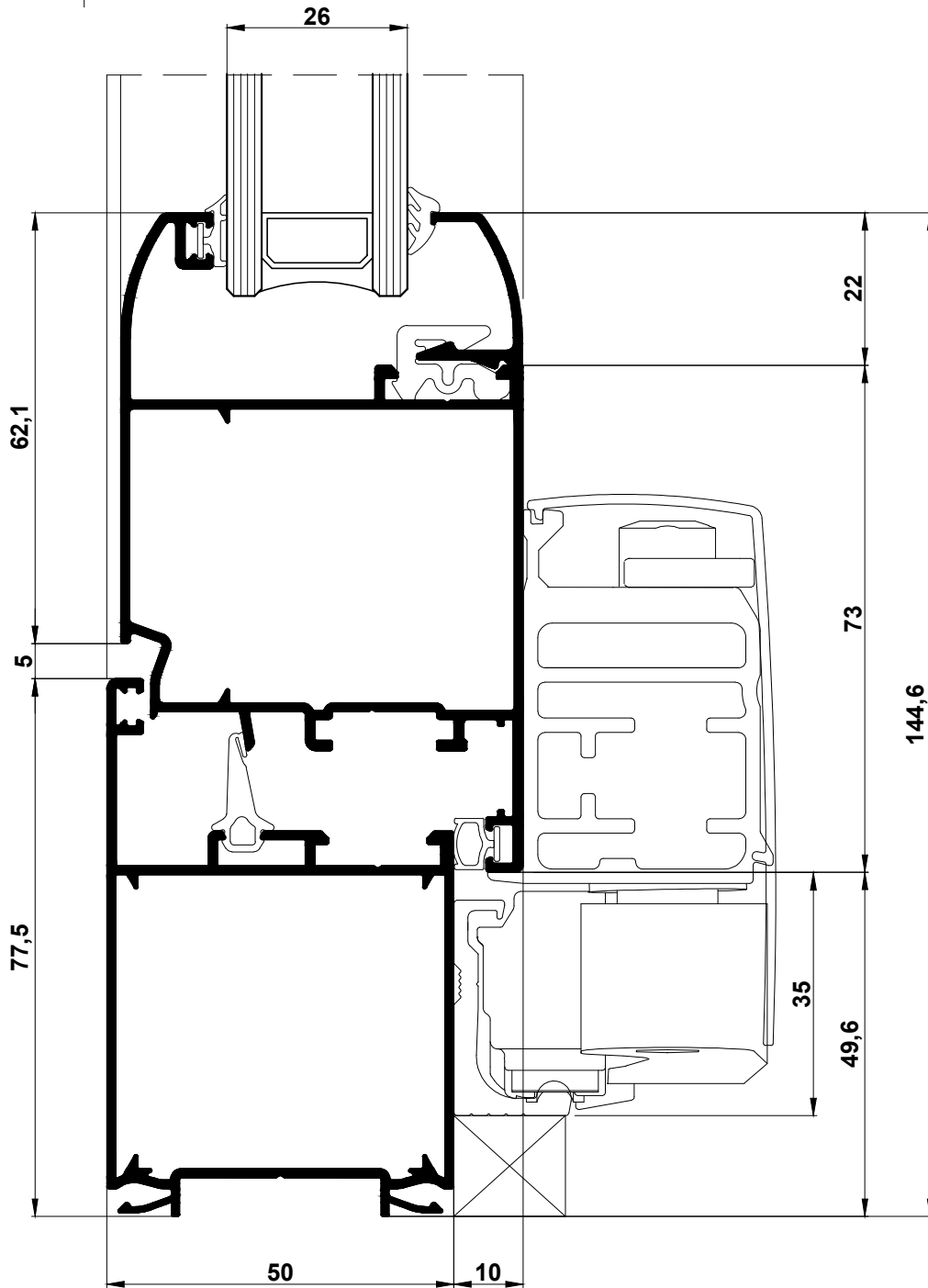
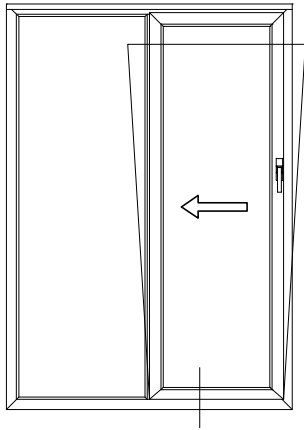

*\*POUR PLUS D'INFORMATIONS CONCERNANT L'USINAGE, VEUILLEZ CONSULTER LE SCHEMA DE MONTAGE SP160*

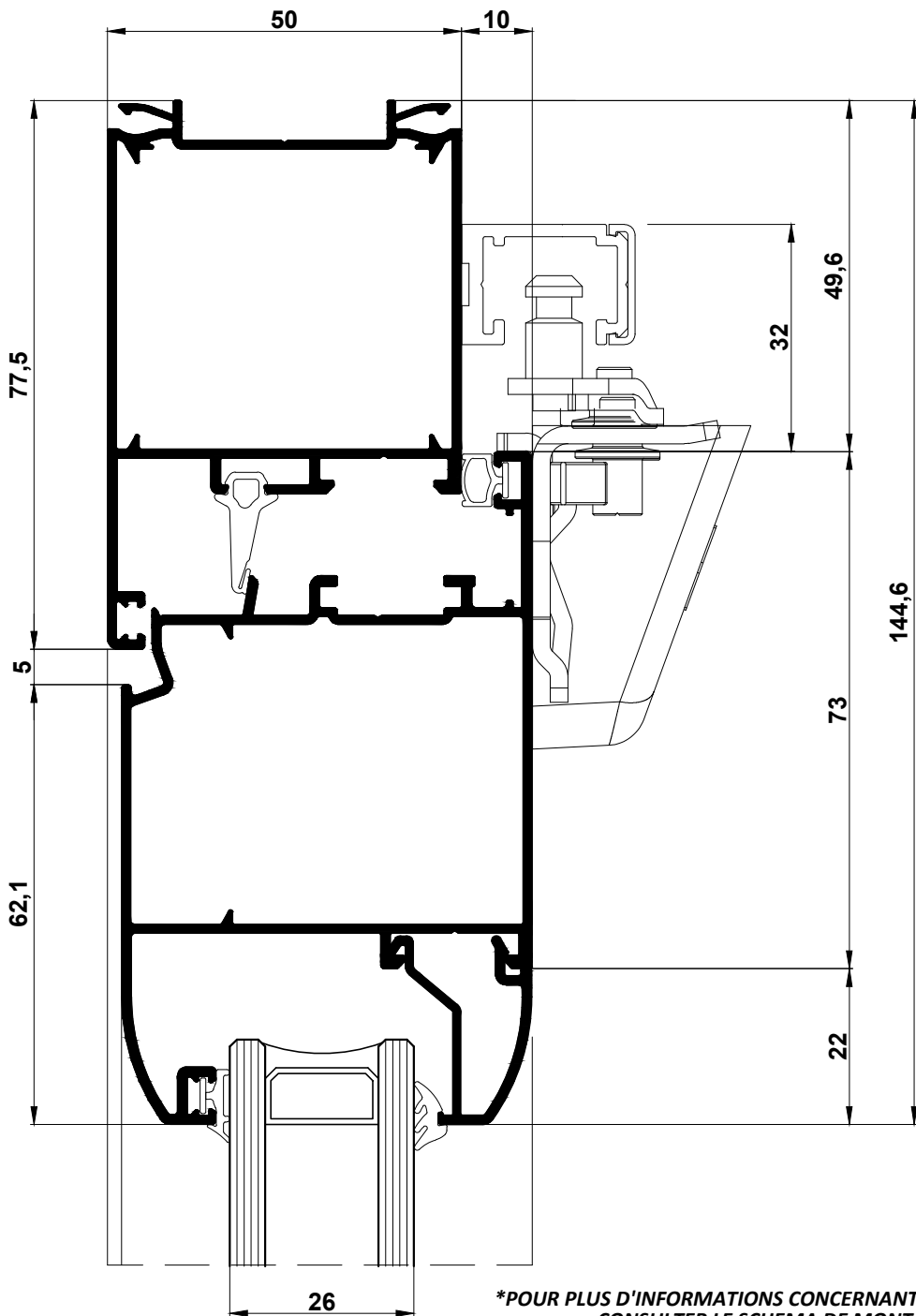
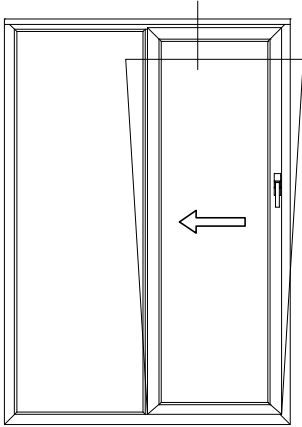

*\*POUR PLUS D'INFORMATIONS CONCERNANT L'USINAGE, VEUILLEZ CONSULTER LE SCHEMA DE MONTAGE SP160*

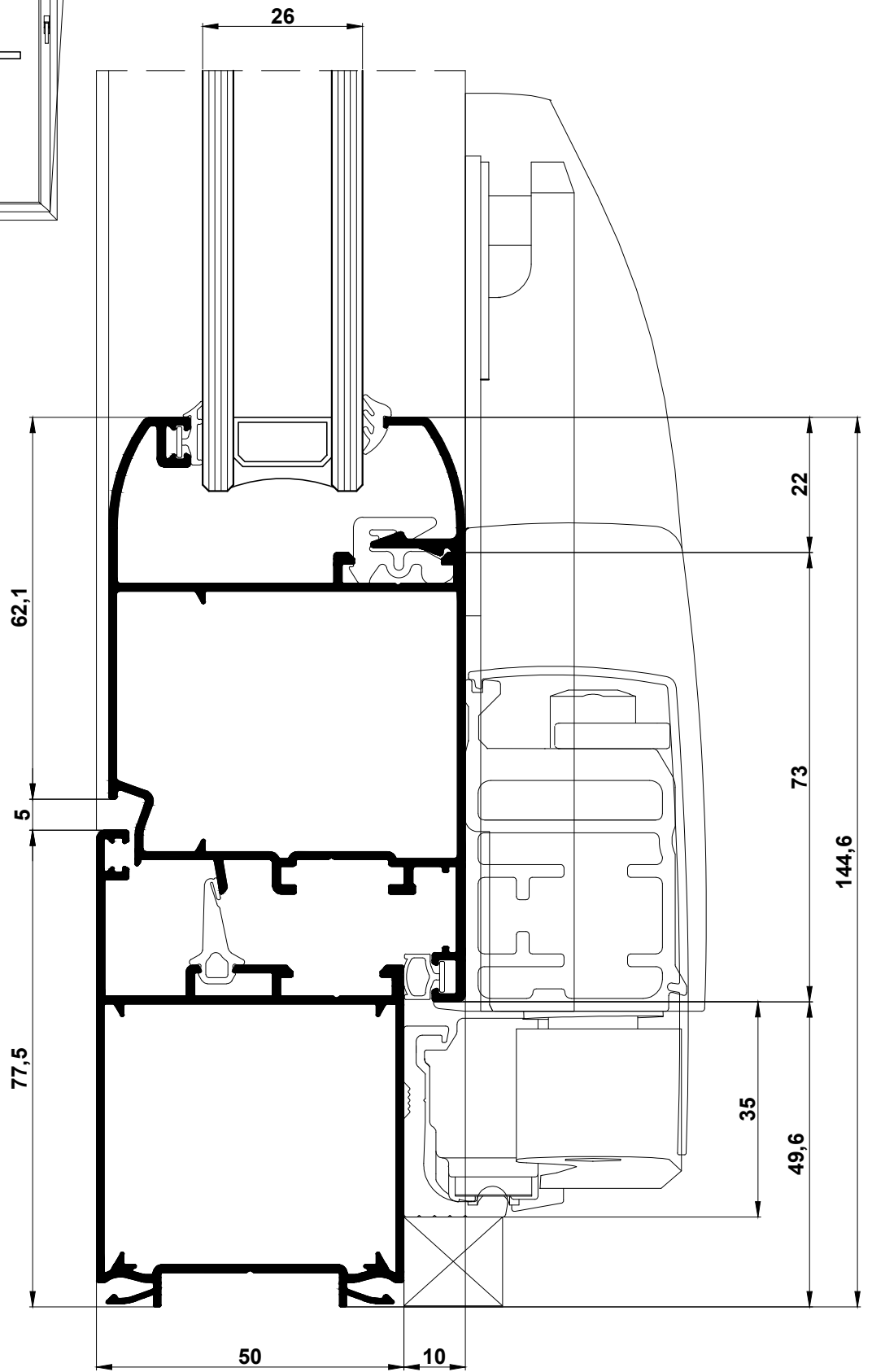
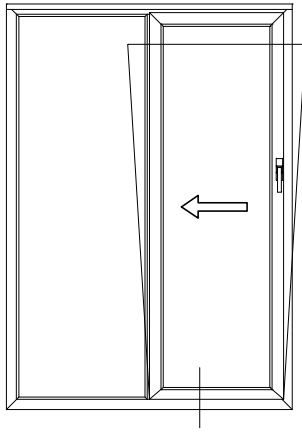

\*POUR PLUS D'INFORMATIONS CONCERNANT L'USINAGE, VEUILLEZ CONSULTER LE SCHEMA DE MONTAGE SP160

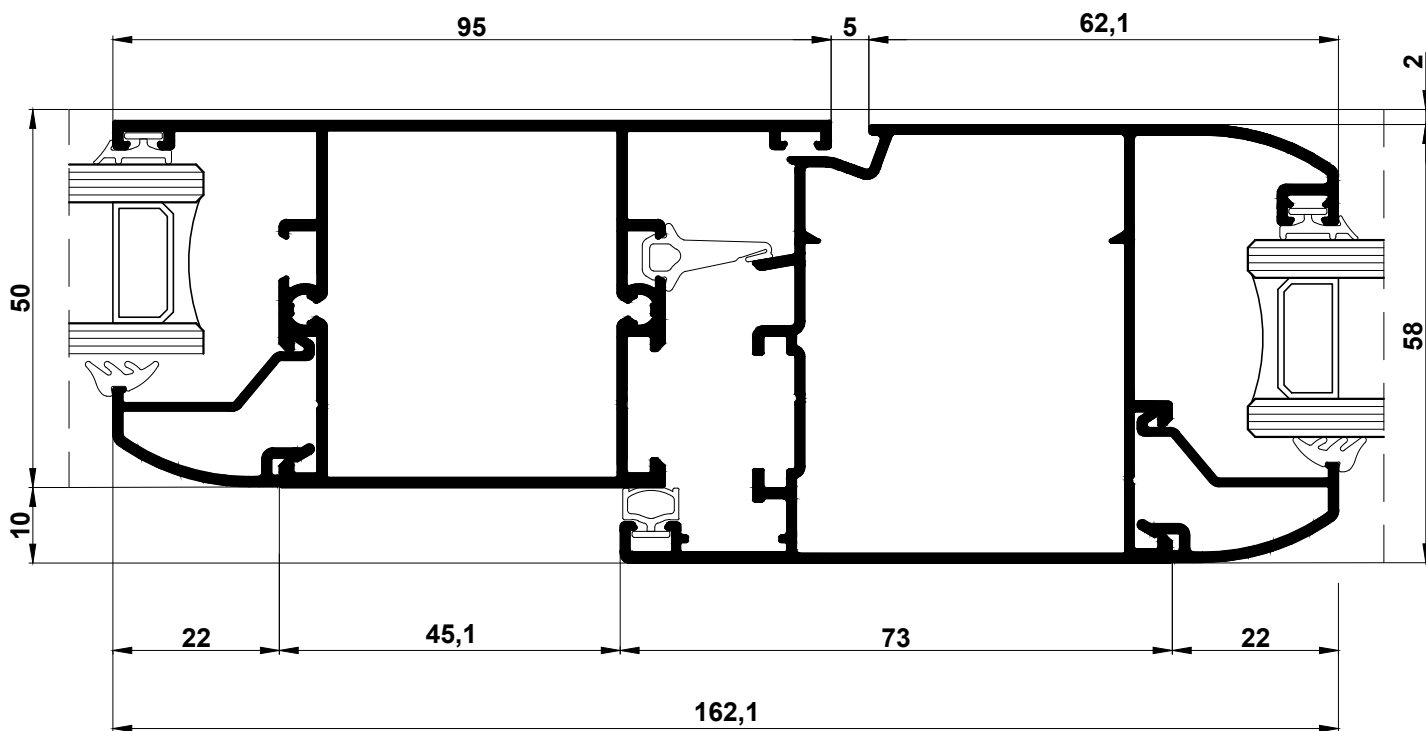
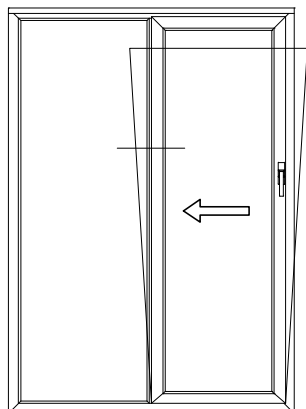

FENETRE BATTANT 1 VANTAIL

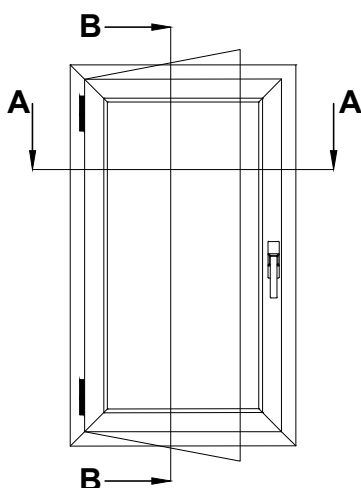

SEC. B-B

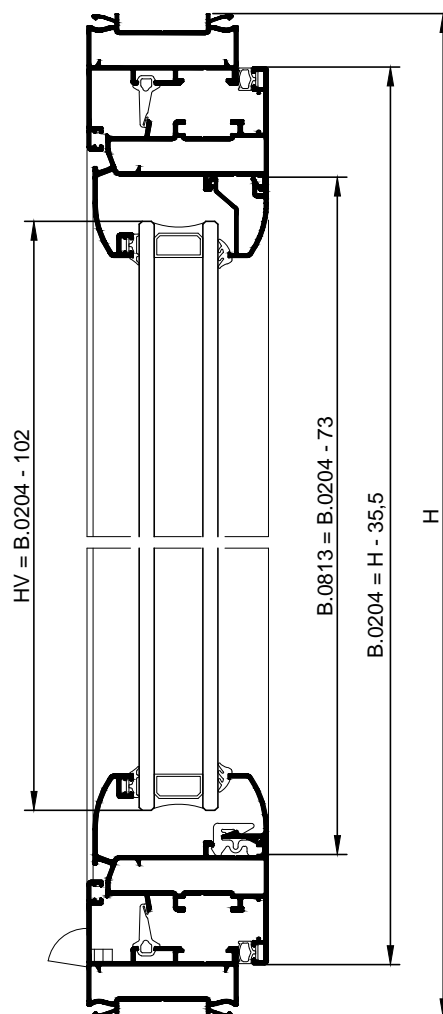



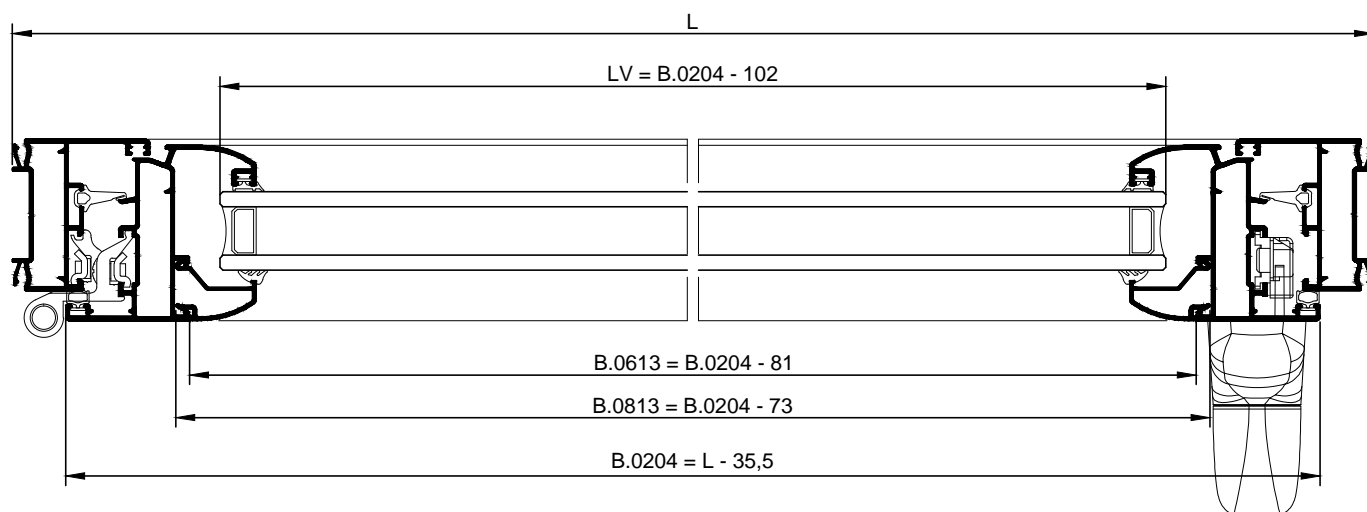

N.B.  
Épaisseur vitrage considérée 26mm  
L Vitrage = B.0204 - 102  
H Vitrage = B.0204 - 102

SEC. A-A

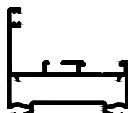
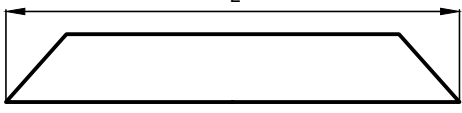
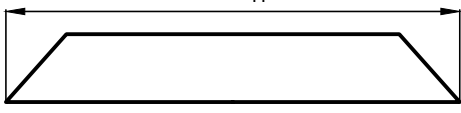
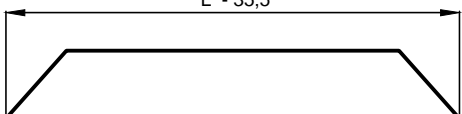
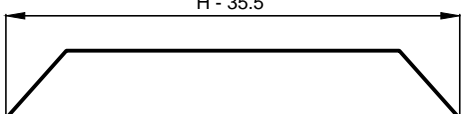

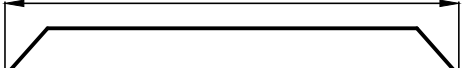
## FENETRE BATTANT 1 VANTAIL

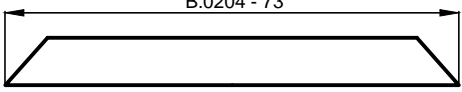
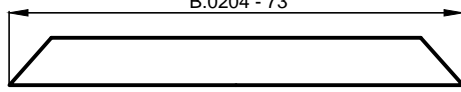
PROFILE	PCS	COUPE	PCS	COUPE
B.0105 	2	 L	2	 H
B.0204 	2	 L - 35,5	2	 H - 35,5
B.0613 	1	 B.0204 - 81		
B.0813 	1	 B.0204 - 73	2	 B.0204 - 73

### ACCESSORIES

REF.	DESCRIPTION	N.	REF.	DESCRIPTION	N.
0311	Equerre dormant	4	9211.3	Paumelle Top Rapid à deux corps	2
0311	Equerre ouvrant	4			
2145	Busette d'évacuation	2			
4032.63	Kit cremone 1 vantail	1			
6008	Crémone Italia	1			

### JOINTS

REF.	DESCRIPTION	L	H	REF.	DESCRIPTION	L	H
IYS27-10	Central	2	2	CF4114	Vitrage interieur	2	2
SY3-247	Battement	2	2	CF4113	Vitrage exterieur	2	2

FENETRE OSCILLOBATTANT 1 VANTAIL

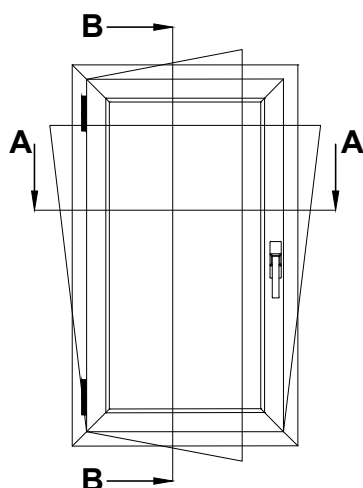

SEC. B-B

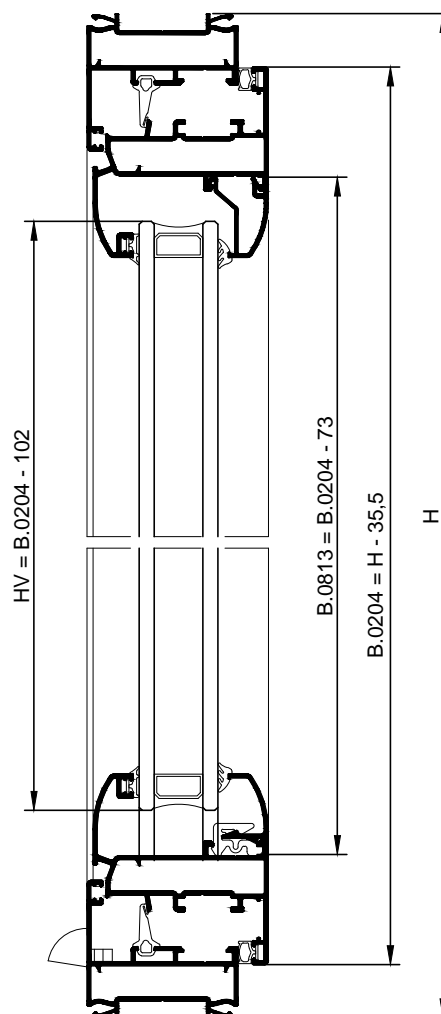



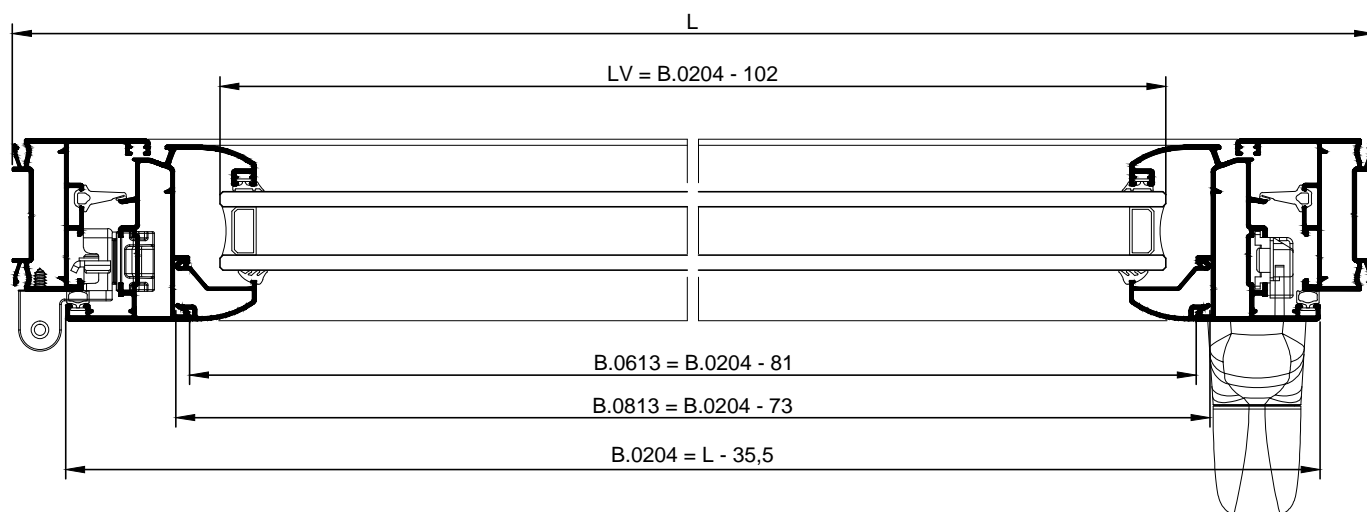

N.B.  
Épaisseur vitrage considérée 26mm  
L Vitrage = B.0204 - 102  
H Vitrage = B.0204 - 102

SEC. A-A



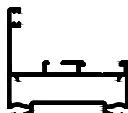
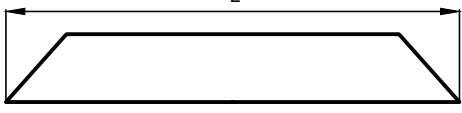
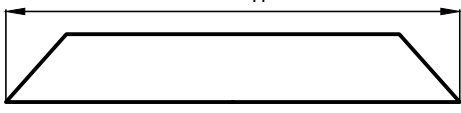
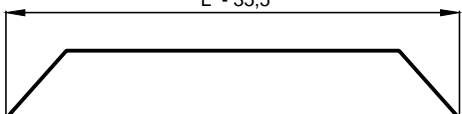
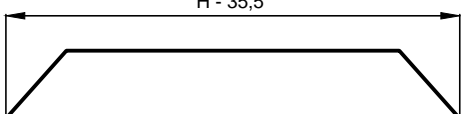

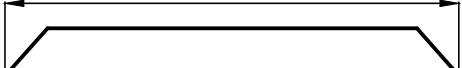
## FENETRE OSCILLOBATTANT 1 VANTAIL

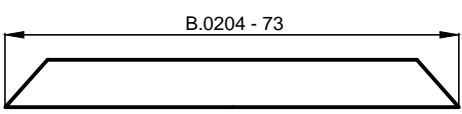
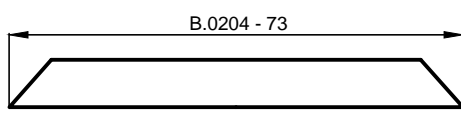
PROFILE	PCS	COUPE	PCS	COUPE
B.0105 	2	 L	2	 H
B.0204 	2	 L - 35,5	2	 H - 35,5
B.0613 	1	 B.0204 - 81		
B.0813 	1	 B.0204 - 73	2	 B.0204 - 73

### ACCESSORIES

REF.	DESCRIPTION	N.	REF.	DESCRIPTION	N.
0311	Equerre dormant	4	3400.20	Bras ob Ween (vantail 370 - 450)	1
0311	Equerre ouvrant	4	3400.21	Bras ob Ween (vantail 451 - 650)	1
2145	Busette d'évacuation	2	3400.22	Bras ob Ween (vantail 651 - 1700)	1
3320F.1	Kit de fermeture Ween	1	6018	Crémone Italia p/oscillo battent	1
3420.24	Kit paumelle ob Ween	1			

### JOINTS

REF.	DESCRIPTION	L	H	REF.	DESCRIPTION	L	H
IYS27-10	Central	2	2	CF4114	Vitrage interieur	2	2
SY3-247	Battement	2	2	CF4113	Vitrage exterieur	2	2

FENETRE SOUFFLET

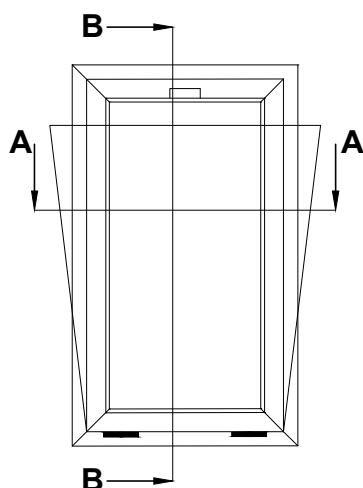

SEC. B-B

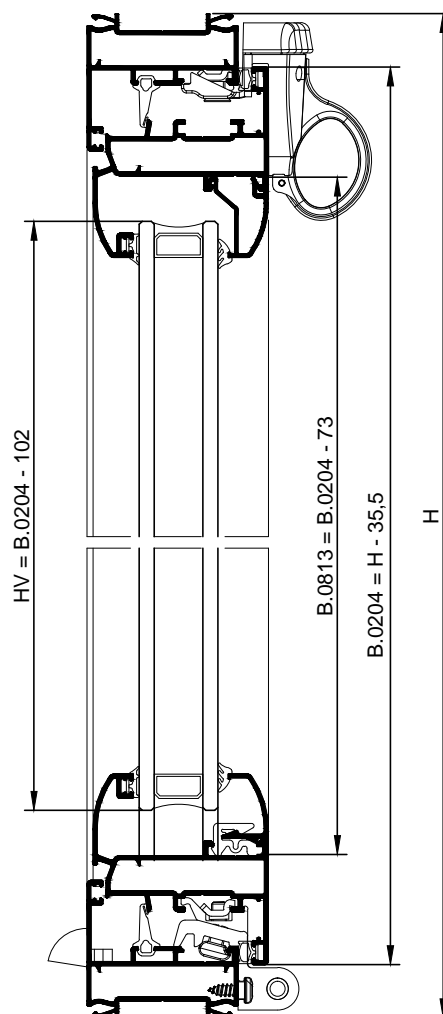

N.B.

Épaisseur vitrage considérée 26mm



L Vitrage = B.0204 - 102

H Vitrage = B.0204 - 102

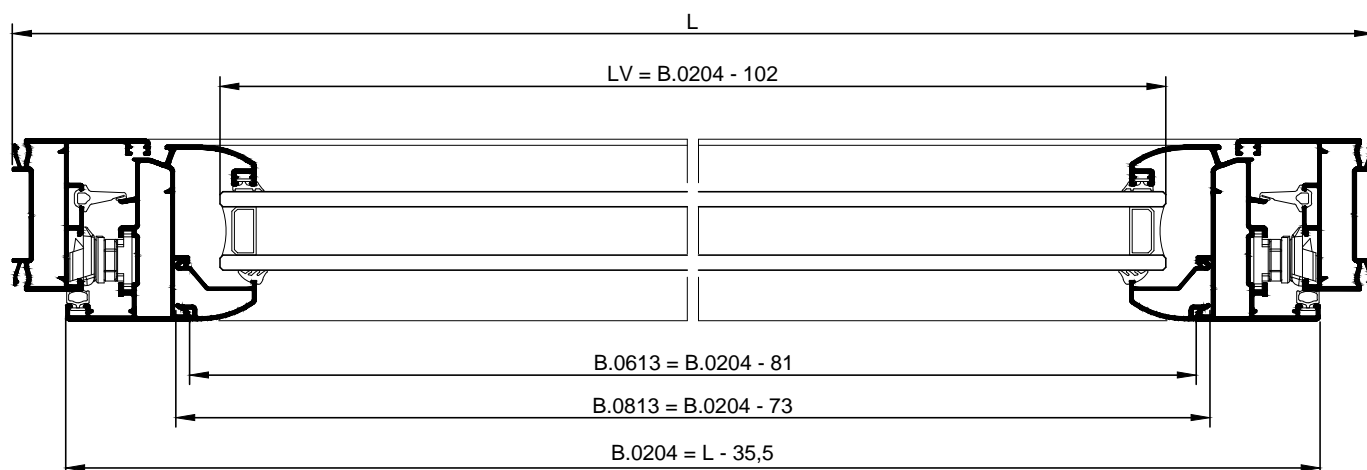
SEC. A-A

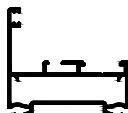
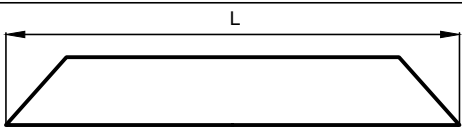
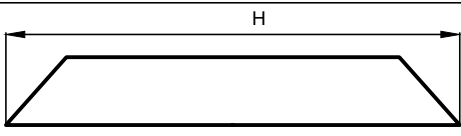
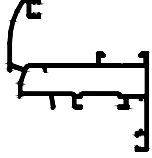
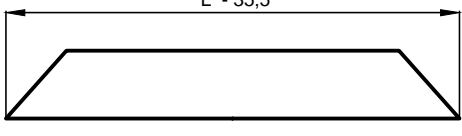
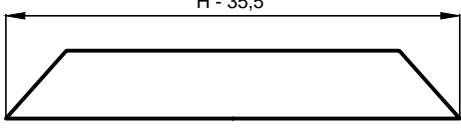

FENETRE SOUFFLET

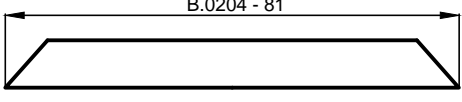
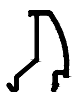
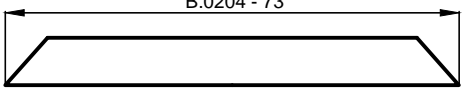
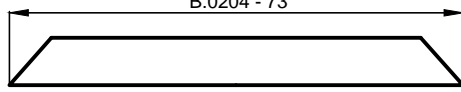
PROFILE	PCS	COUPE	PCS	COUPE
B.0105 	2		2	
B.0204 	2		2	
B.0613 	1			
B.0813 	1		2	

ACCESSORIES

REF.	DESCRIPTION	N.	REF.	DESCRIPTION	N.
0311	Equerre dormant	4	3420.71	Paumelle à peigne	2
0311	Equerre ouvrant	4			
2145	Busette d'évacuation	2			
1115.1	Bras limiteur d'ouverture vantail hauteur 600 à 1600	1 cp			
1500.5	Cliquet en zamak	1			

JOINTS

REF.	DESCRIPTION	L	H	REF.	DESCRIPTION	L	H
IYS27-10	Central	2	2	CF4114	Vitrage interieur	2	2
SY3-247	Battement	2	2	CF4113	Vitrage exterieur	2	2

FENETRE BATTANT 2 VANTAUX

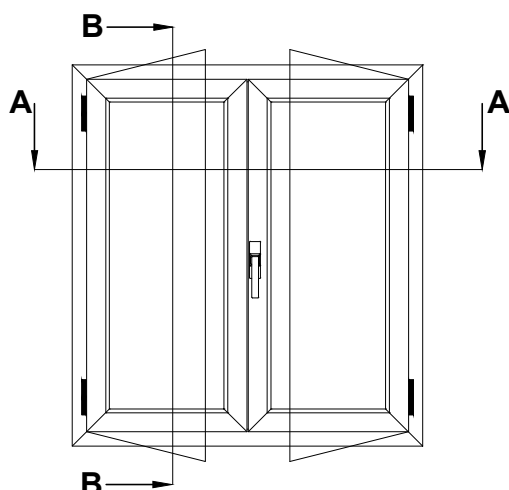

SEC. B-B

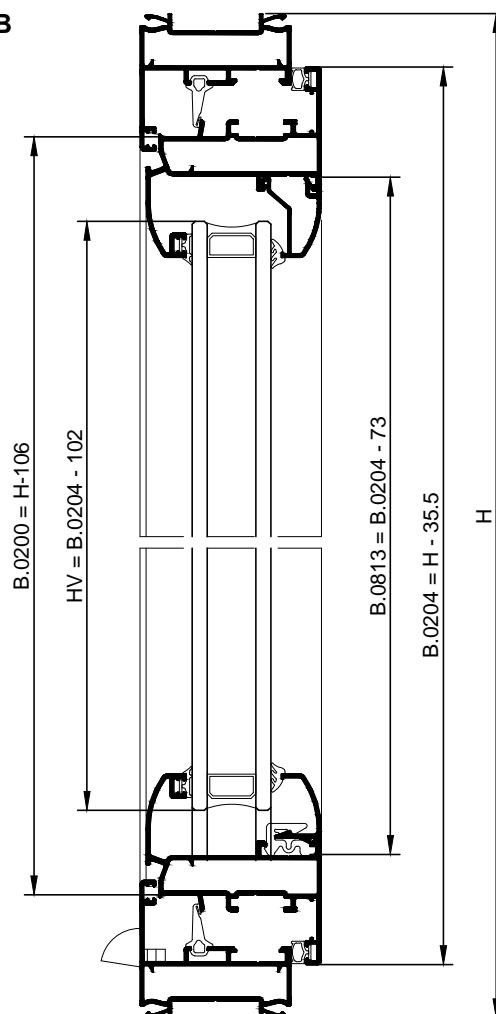





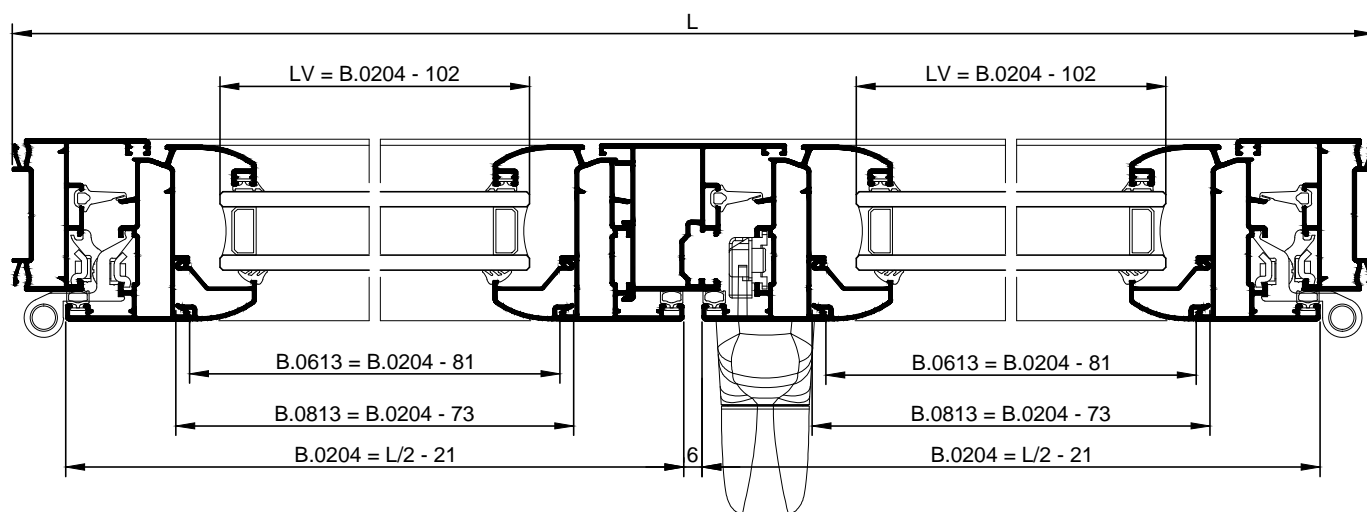

N.B.  
 Épaisseur vitrage considérée 26mm  
 L Vitrage = B.0204 - 102  
 H Vitrage = B.0204 - 102

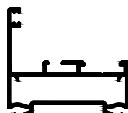
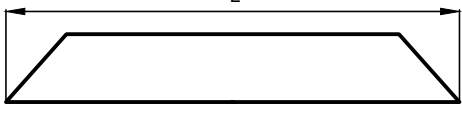
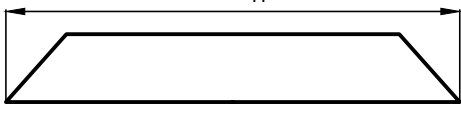
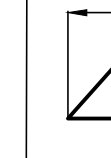
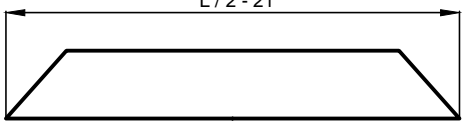
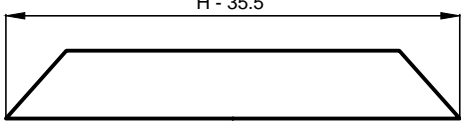
SEC. A-A

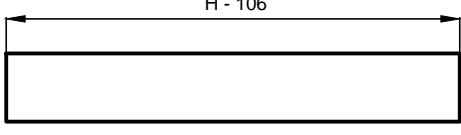

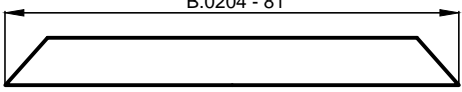
## FENETRE BATTANT 2 VANTAUX

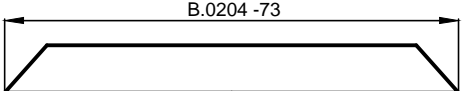
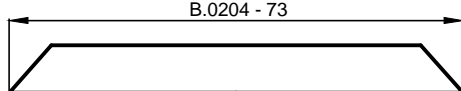
PROFILE	PCS	COUPE	PCS	COUPE
B.0105 	2	 L	2	 H
B.0204 	4	 L / 2 - 21	4	 H - 35.5
B.0200 			1	 H - 106
B.0613 	2	 B.0204 - 81		
B.0813 	2	 B.0204 - 73	4	 B.0204 - 73

### ACCESSORIES

REF.	DESCRIPTION	N.	REF.	DESCRIPTION	N.
0311	Equerre dormant	4	6008	Crémone Italia	1
0311	Equerre ouvrant	8	4515.1	Verrou a levier bi-directionnel	1
PP2081.10	Embout battement central	1	4206	Double gache crémone	2
2145	Busette d'évacuation	2	9211.3	Paumelle Top Rapid à deux corps	4
4032.63	Kit cremone 1 vantail	1			

### JOINTS

REF.	DESCRIPTION	L	H	REF.	DESCRIPTION	L	H
IYS27-10	Central	2	3	CF4114	Vitrage interieur	2	4
SY3-247	Battement	2	4	CF4113	Vitrage exterieur	2	4

FENETRE OSCILLOBATTANT 2 VANTAUX

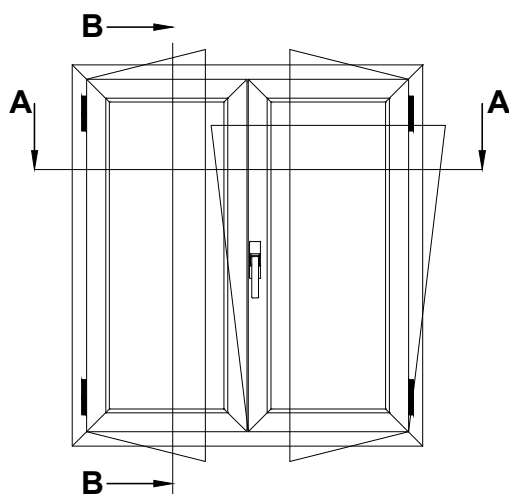

SEC. B-B

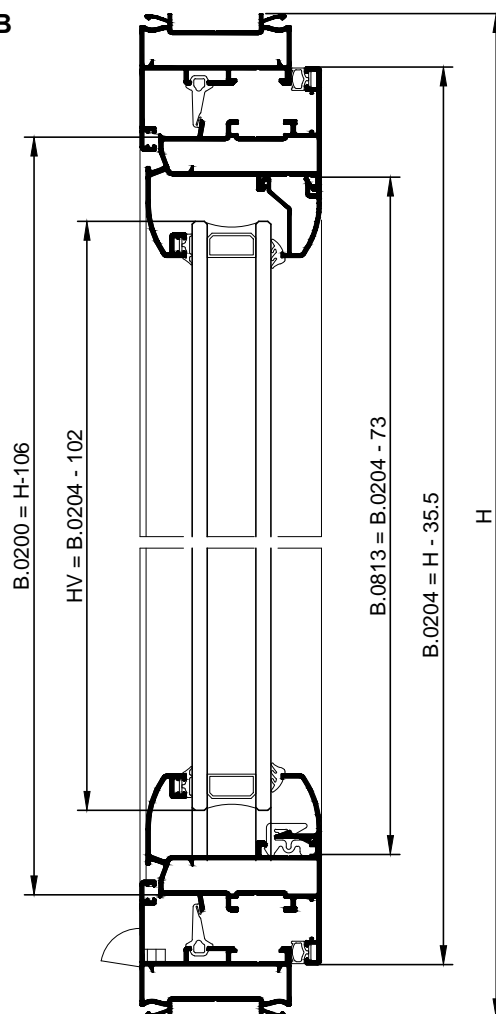





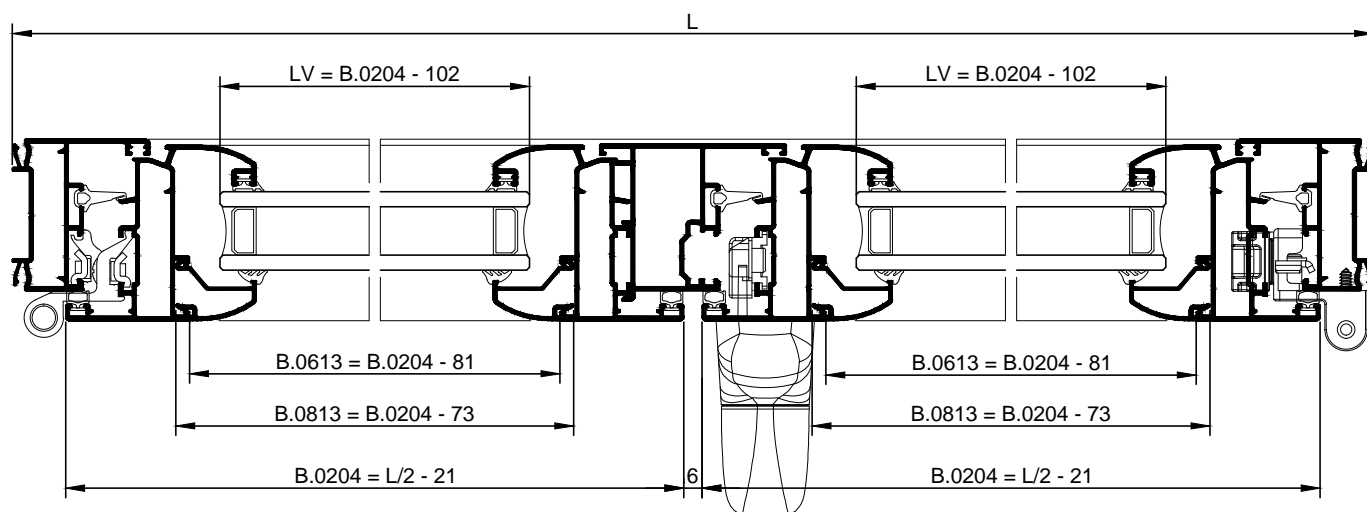

N.B.  
Épaisseur vitrage considérée 26mm  
L Vitrage = B.0204 - 102  
H Vitrage = B.0204 - 102

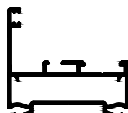
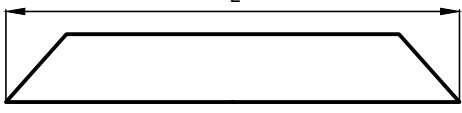
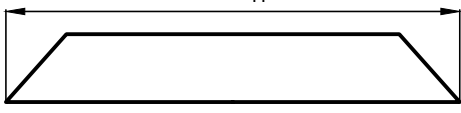
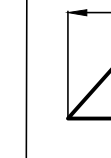
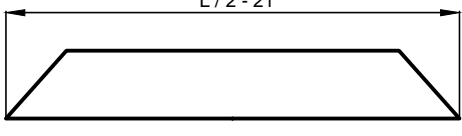
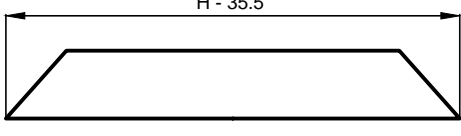
SEC. A-A

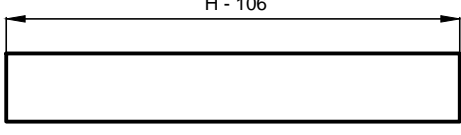

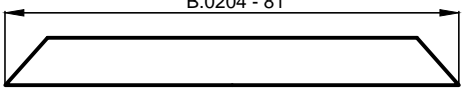
## FENETRE OSCILLOBATTANT 2 VANTAUX

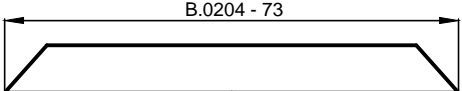
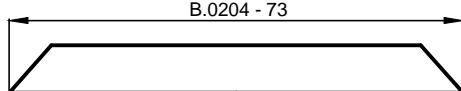
PROFILE	PCS	COUPE	PCS	COUPE
B.0105 	2	 L	2	 H
B.0204 	4	 L / 2 - 21	4	 H - 35.5
B.0200 			1	 H - 106
B.0613 	2	 B.0204 - 81		
B.0813 	2	 B.0204 - 73	4	 B.0204 - 73

### ACCESSORIES

REF.	DESCRIPTION	N.	REF.	DESCRIPTION	N.
0311	Equerre dormant	4	3420.24	Kit paumelle ob Ween	1
0311	Equerre ouvrant	8	3400.20	Bras ob Ween (vantaill 370 - 450)	1
PP2081.10	Embout battement central	1	3400.21	Bras ob Ween (vantaill 451 - 650)	1
2145	Busette d'évacuation	2	3400.22	Bras ob Ween (vantaill 651 - 1700)	1
3320F.1	Kit de fermeture Ween	1	4515.1	Verrou a levier bi-directionnel	1
3420.23	Kit paumelle ob Ween vantaill semi fixe	1	4206	Double gache crémone	1

### JOINTS

REF.	DESCRIPTION	L	H	REF.	DESCRIPTION	L	H
IYS27-10	Central	2	3	CF4114	Vitrage interieur	2	4
SY3-247	Battement	2	4	CF4113	Vitrage exterieur	2	4

FENETRE BATTANT 2 VANTAUX (bas profile central)

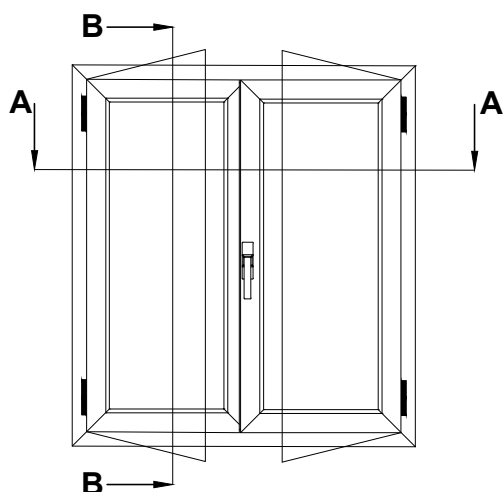

SEC. B-B

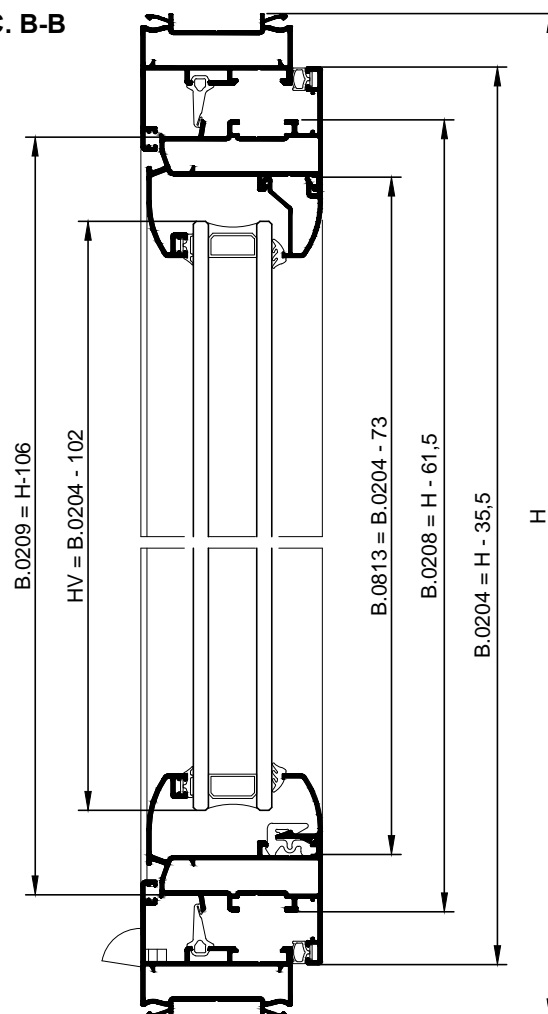





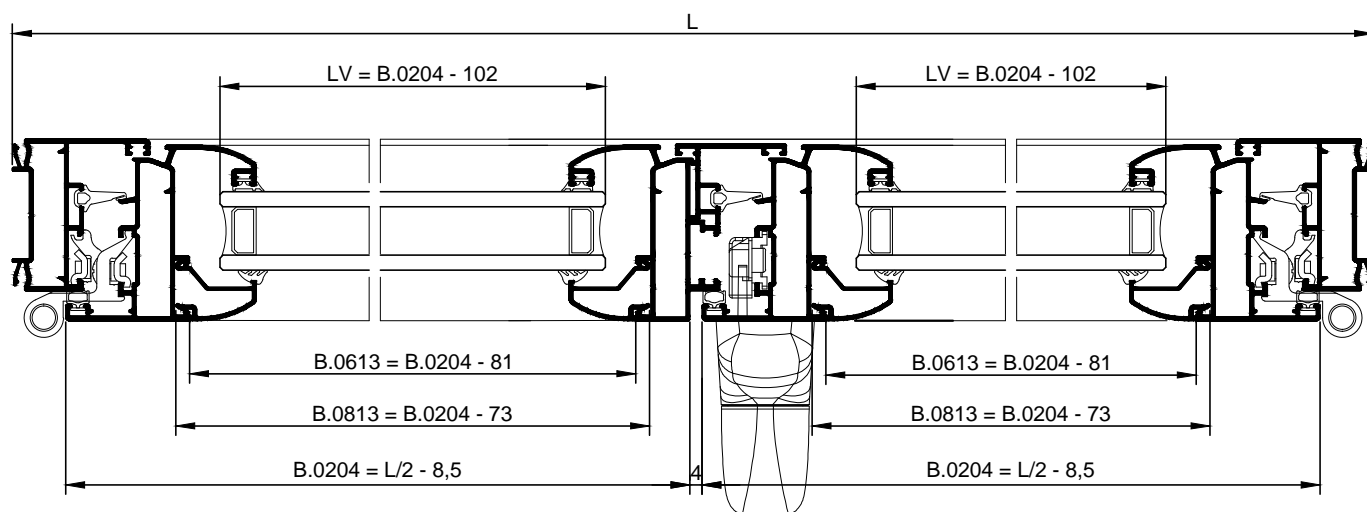

N.B.  
 Épaisseur vitrage considérée 26mm  
 L Vitrage = B.0204 - 102  
 H Vitrage = B.0204 - 102

SEC. A-A

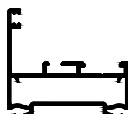
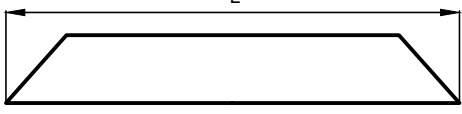
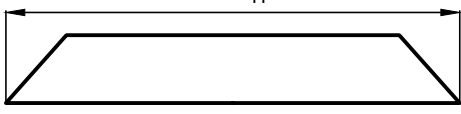
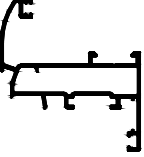
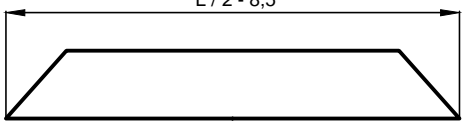
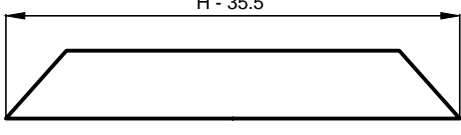
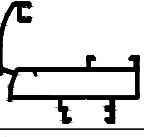
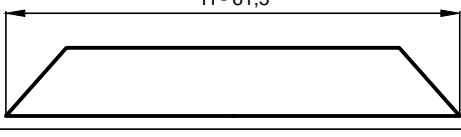

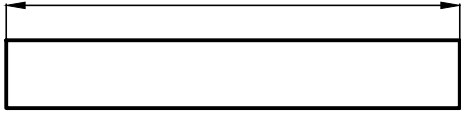

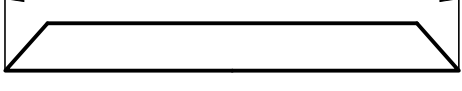
## FENETRE BATTANT 2 VANTAUX (bas profile central)

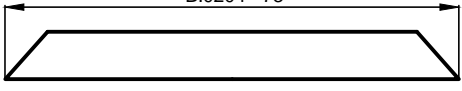
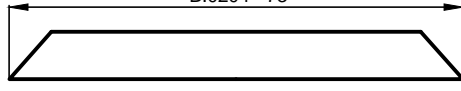
PROFILE	PCS	COUPE	PCS	COUPE
B.0105 	2	 L	2	 H
B.0204 	4	 L / 2 - 8,5	3	 H - 35,5
B.0208 			1	 H - 61,5
B.0209 			1	 H - 106
B.0613 	2	 B.0204 - 81		
B.0813 	2	 B.0204 - 73	4	 B.0204 - 73

### ACCESSORIES

REF.	DESCRIPTION	N.	REF.	DESCRIPTION	N.
0311	Equerre dormant	4	6008	Crémone Italia	1
0311	Equerre ouvrant	8	4515.1	Verrou a levier bi-directionnel	1
PP2081.11	Embout battement central réduit	1	4206	Double gache crémone	2
2145	Busette d'évacuation	2	9211.3	Paumelle Top Rapid à deux corps	4
4032.63	Kit cremone 1 vantail	1			

### JOINTS

REF.	DESCRIPTION	L	H	REF.	DESCRIPTION	L	H
IYS27-10	Central	2	3	CF4114	Vitrage interieur	2	4
SY3-247	Battement	2	4	CF4113	Vitrage exterieur	2	4

FENETRE OSCILLOBATTANT 2 VANTAUX (bas profile central)

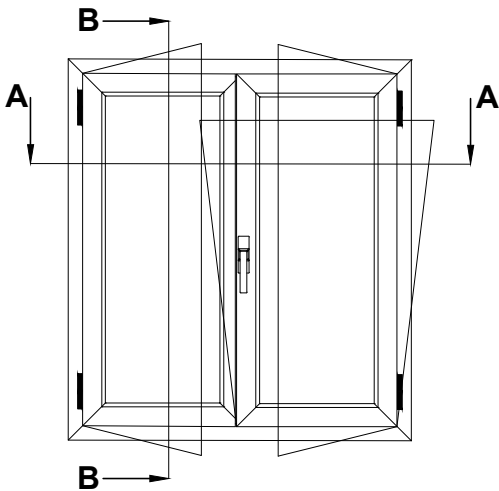

SEC. B-B

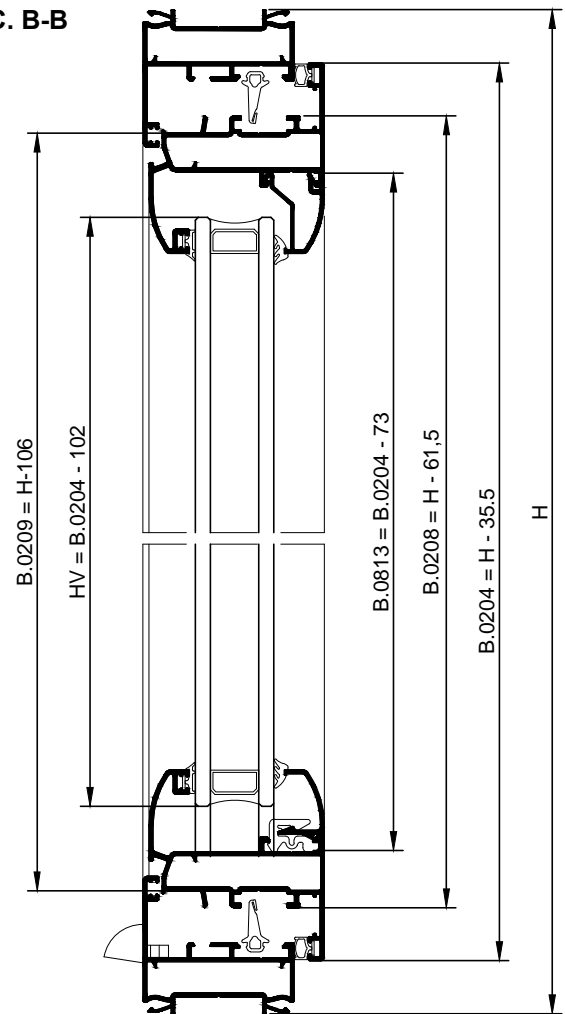



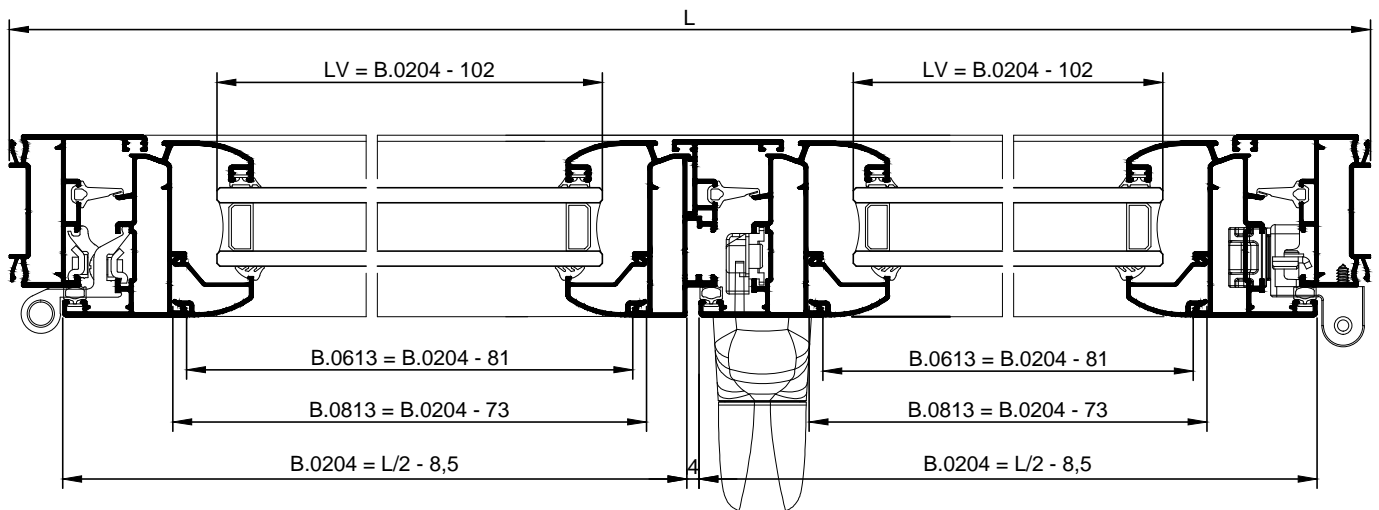

N.B.  
 Épaisseur vitrage considérée 26mm  
 L Vitrage = B.0204 - 102  
 H Vitrage = B.0204 - 102

SEC. A-A

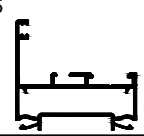
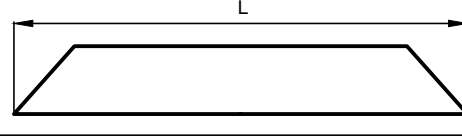
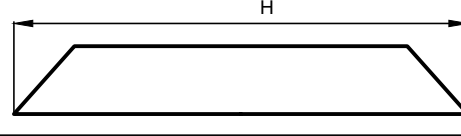
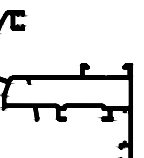
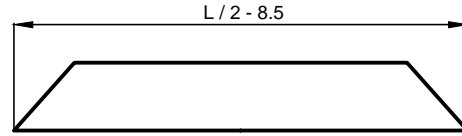
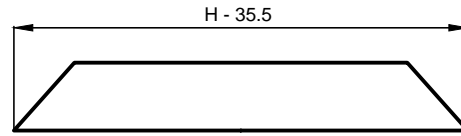
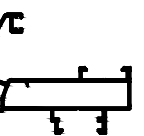
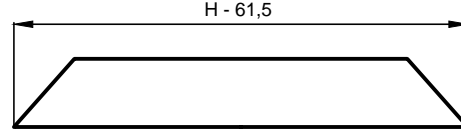
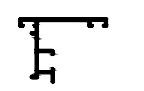
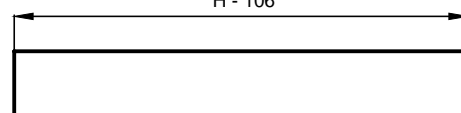

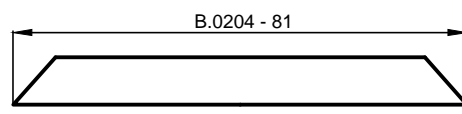
## FENETRE OSCILLOBATTANT 2 VANTAUX (bas profile central)

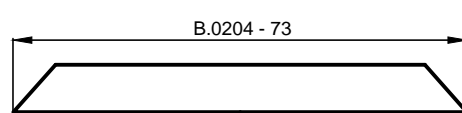
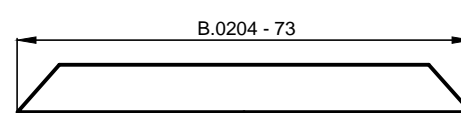
PROFILE	PCS	COUPE	PCS	COUPE
B.0105 	2	 L	2	 H
B.0204 	4	 L / 2 - 8.5	4	 H - 35.5
B.0208 				 H - 61,5
B.0209 			1	 H - 106
B.0613 	2	 B.0204 - 81		
B.0813 	2	 B.0204 - 73	4	 B.0204 - 73

### ACCESSORIES

REF.	DESCRIPTION	N.	REF.	DESCRIPTION	N.
0311	Equerre dormant	4	3420.24	Kit paumelle ob Ween	1
0311	Equerre ouvrant	8	3400.20	Bras ob Ween (vantaill 370 - 450)	1
PP2081.11	Embout battement central réduit	1	3400.21	Bras ob Ween (vantaill 451 - 650)	1
2145	Busette d'évacuation	2	3400.22	Bras ob Ween (vantaill 651 - 1700)	1
3320F.1	Kit de fermeture Ween	1	4515.1	Verrou a levier bi-directionnel	1
3420.23	Kit paumelle ob Ween vantaill semi fixe	1	4206	Double gache crémone	1

### JOINTS

REF.	DESCRIPTION	L	H	REF.	DESCRIPTION	L	H
IYS27-10	Central	2	3	CF4114	Vitrage interieur	2	4
SY3-247	Battement	2	4	CF4113	Vitrage exterieur	2	4

## PORTE OUVERTURE INTERIEUR 1 VANTAIL

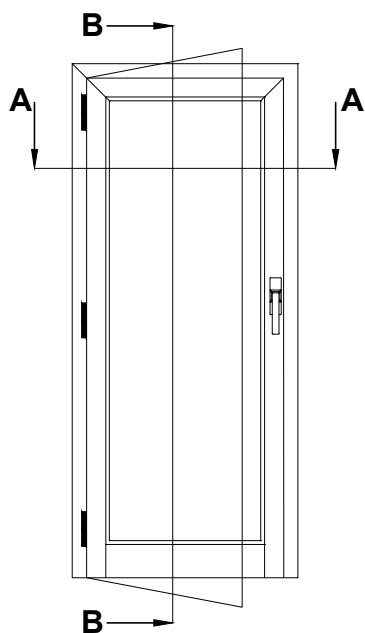

SEC. B-B

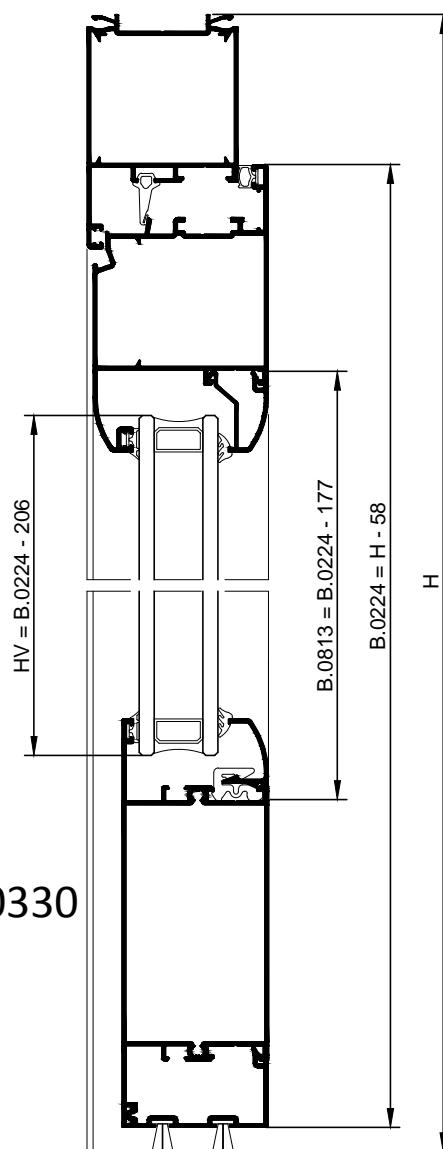





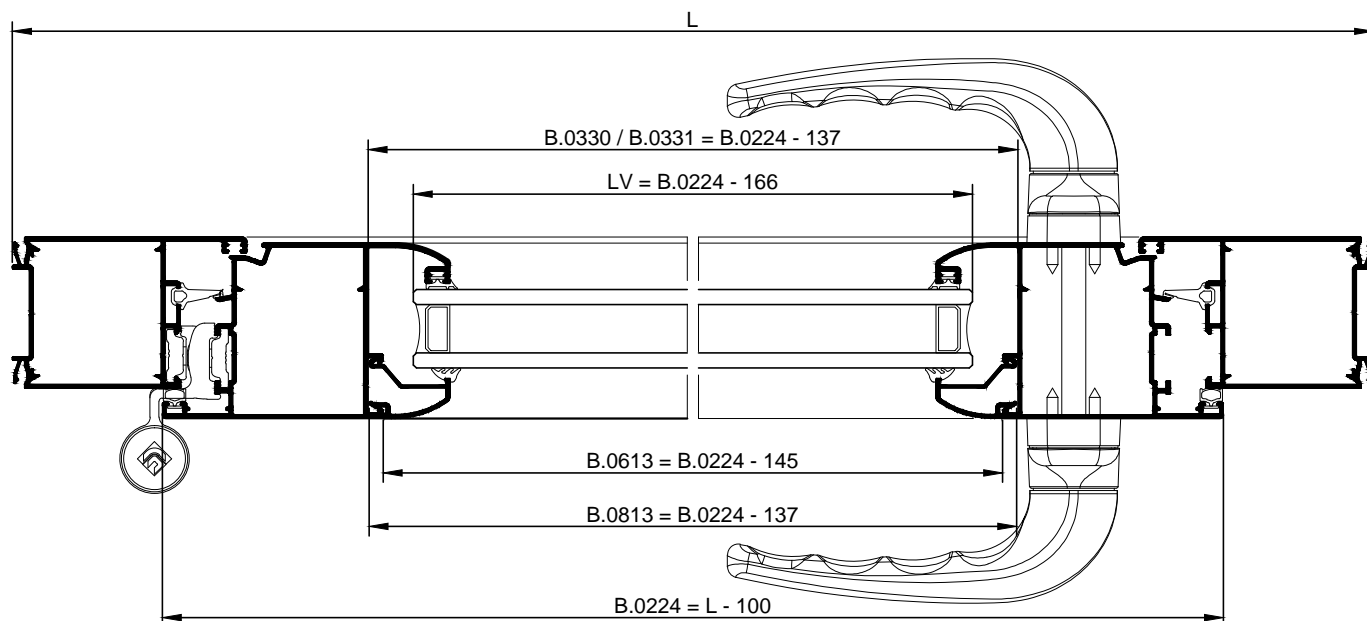

N.B.  
Épaisseur vitrage considérée 26mm  
L Vitrage = B.0224 - 166  
H Vitrage = B.0224 - 206

B.0330

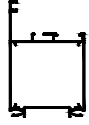
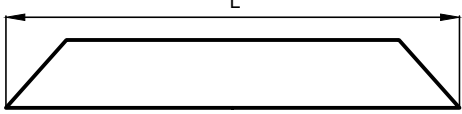
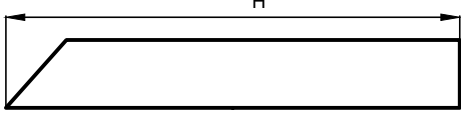
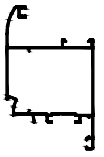
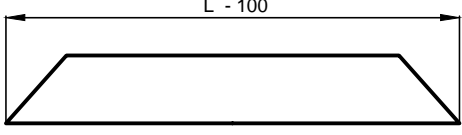
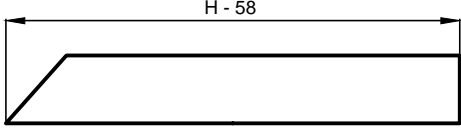
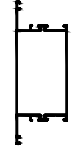
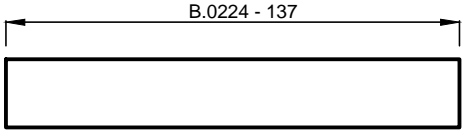
SEC. A-A

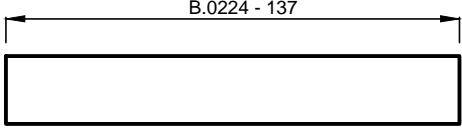

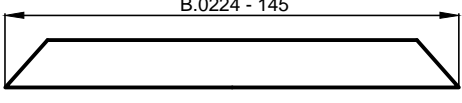
## PORTE OUVERTURE INTERIEUR 1 VANTAIL

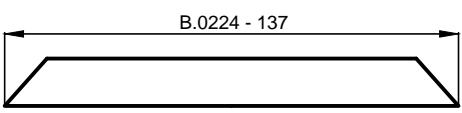
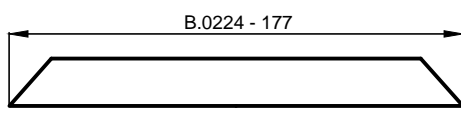
PROFILE	PCS	COUPE	PCS	COUPE
B.0125 	1	 L	2	 H
B.0224 	1	 L - 100	2	 H - 58
B.0330 	1	 B.0224 - 137		
B.0331 	1	 B.0224 - 137		
B.0613 	1	 B.0224 - 145		
B.0813 	1	 B.0224 - 137	2	 B.0224 - 177

### ACCESSORIES

REF.	DESCRIPTION	N.	REF.	DESCRIPTION	N.
0311	Equerre dormant	2	3065	Double bequille Italia	1
A0280	Supplément equerre dormant	2	2129.4	Cache cylindre Italia	2
0311	Equerre ouvrant	2			
A0280	Supplément equerre ouvrant	2			
8060	Paumelle Slim Rapid à deux corps	2*			

### JOINTS

REF.	DESCRIPTION	L	H	REF.	DESCRIPTION	L	H
IYS27-10	Central	1	2	CF4114	Vitrage interieur	2	2
SY3-247	Battement	1	2	CF4113	Vitrage exterieur	2	2
AG1503A	Joint brosse	2		<b>*VUILLEZ CONSULTER LE TABLEAU DE CHARGE</b>			

PORTE OUVERTURE INTERIEUR 1 VANTAIL

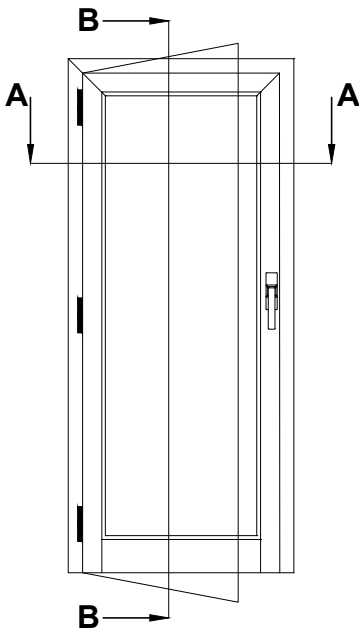

SEC. B-B

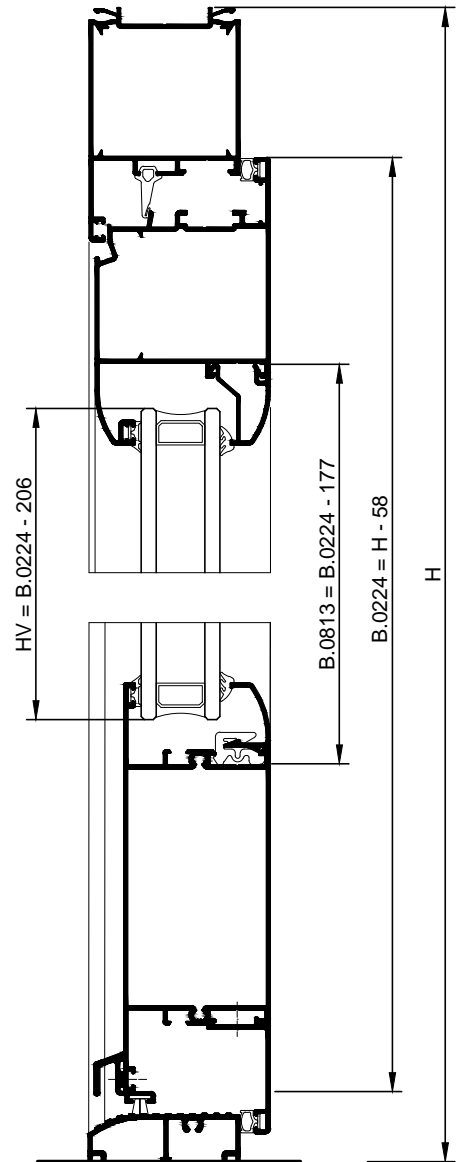





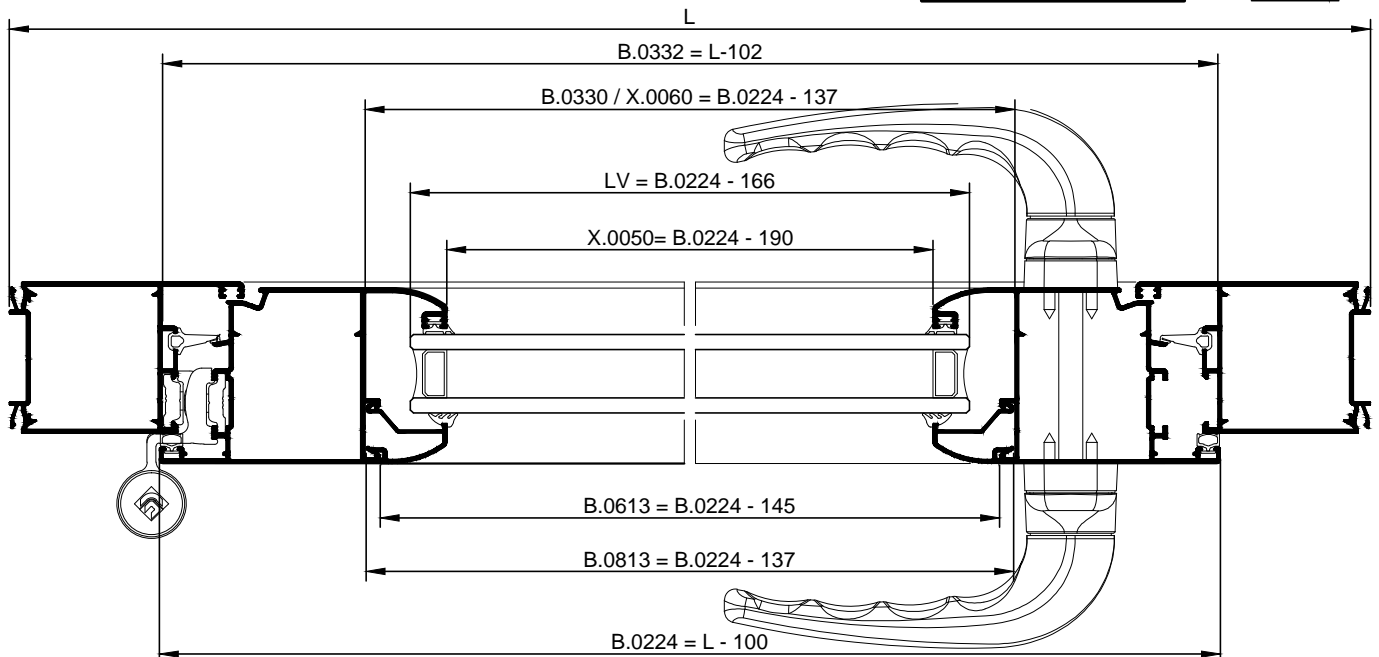

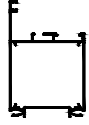
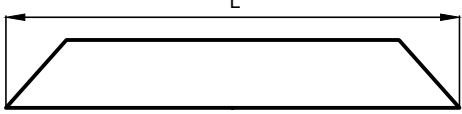
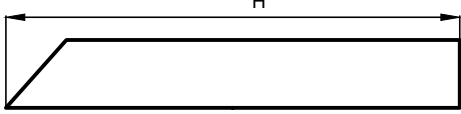
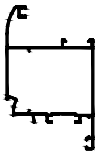
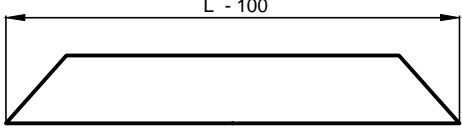
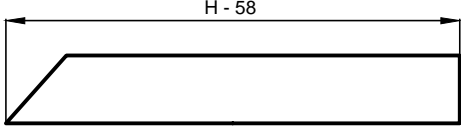
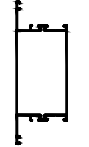
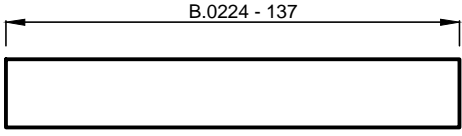

N.B.  
Épaisseur vitrage considérée 26mm  
L Vitrage = B.0224 - 166  
H Vitrage = B.0224 - 206

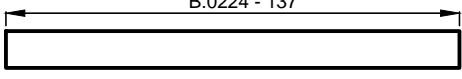
SEC. A-A

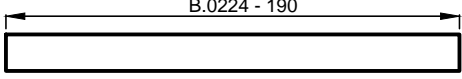
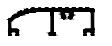
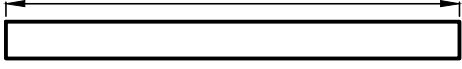

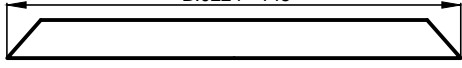
## PORTE OUVERTURE INTERIEUR 1 VANTAIL

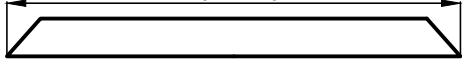
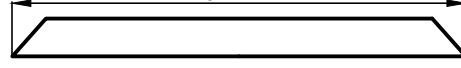
PROFILE	PCS	COUPE	PCS	COUPE
B.0125 	1	 L	2	 H
B.0224 	1	 L - 100	2	 H - 58
B.0330 	1	 B.0224 - 137		
X.0060 	1	 B.0224 - 137		
X.0050 	1	 B.0224 - 190		
B.0332 	1	 L - 102		
B.0613 	1	 B.0224 - 145		
B.0813 	1	 B.0224 - 137	2	 B.0224 - 177

### ACCESSORIES

REF.	DESCRIPTION	N.	REF.	DESCRIPTION	N.
0311	Equerre dormant	2	3065	Double bequille Italia	1
A0280	Supplément equerre dormant	2	2129.4	Cache cylindre Italia	2
0311	Equerre ouvrant	2			
A0280	Supplément equerre ouvrant	2			
8060	Paumelle Slim Rapid à deux corps	2*			

### JOINTS

REF.	DESCRIPTION	L	H	REF.	DESCRIPTION	L	H
IYS27-10	Central	1	2	CF4114	Vitrage interieur	2	2
SY3-247	Battement	1	2	CF4113	Vitrage exterieur	2	2
AG1503A	Joint brosse	2		<b>*VUILLEZ CONSULTER LE TABLEAU DE CHARGE</b>			

## PORTE OUVERTURE INTERIEUR 2 VANTAUX

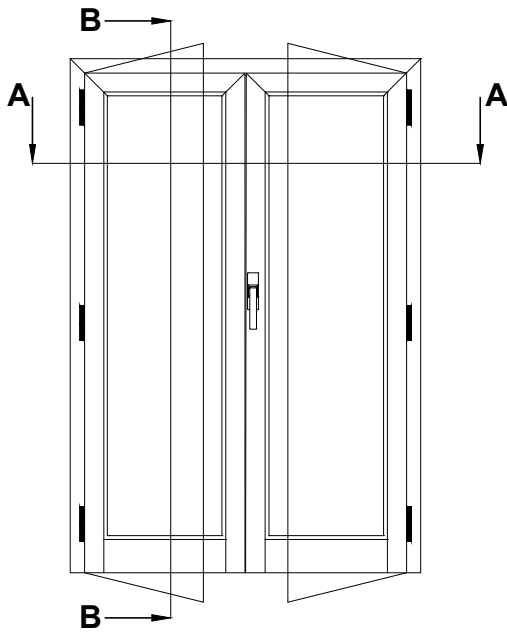

SEC. B-B

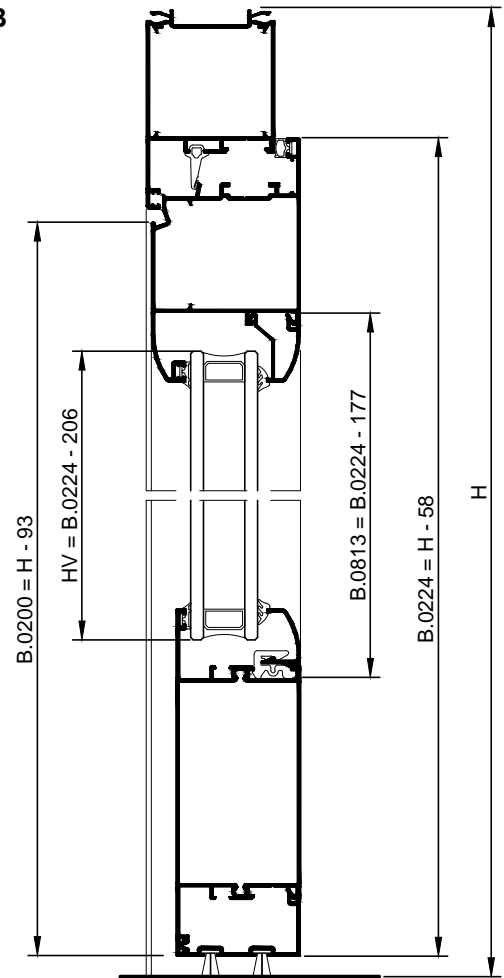

N.B.

Épaisseur vitrage considérée 26mm

L Vitrage = B.0224 - 166





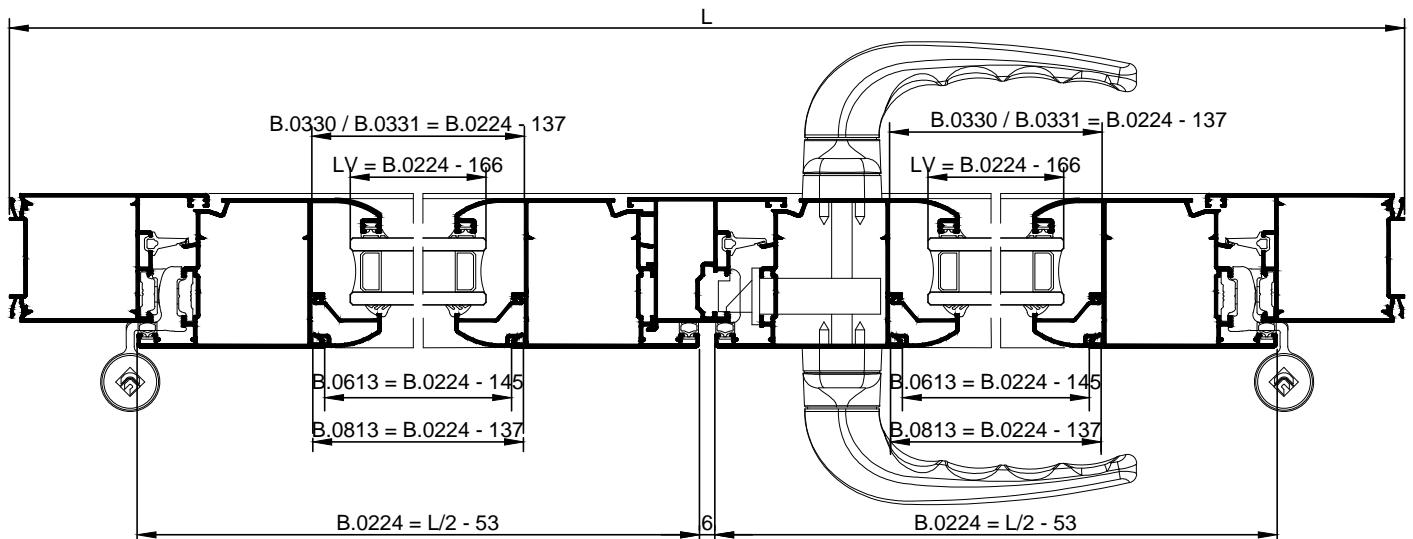

H Vitrage = B.0224 - 206

SEC. A-A

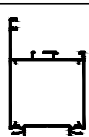
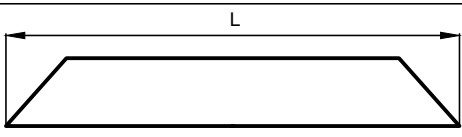
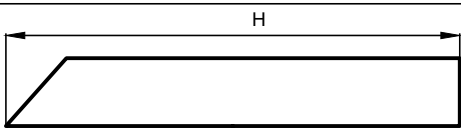
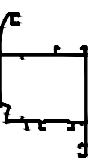
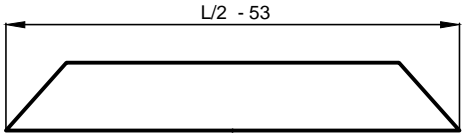
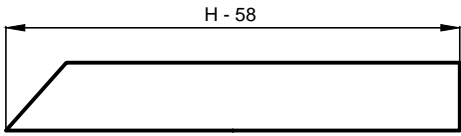
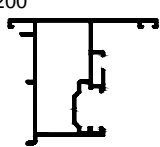
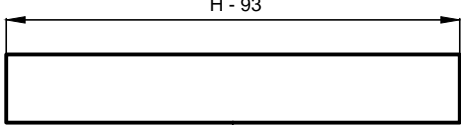
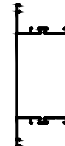
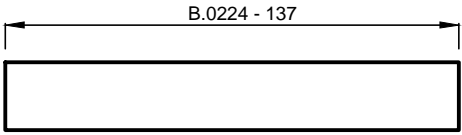

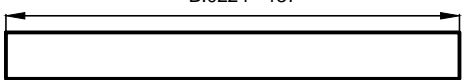

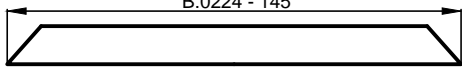
## PORTE OUVERTURE INTERIEUR 2 VANTAUX

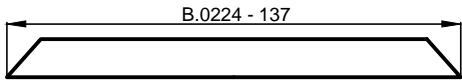
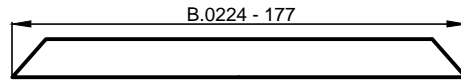
PROFILE	PCS	COUPE	PCS	COUPE
B.0125 	1	 L	2	 H
B.0224 	2	 L/2 - 53	4	 H - 58
B.0200 			1	 H - 93
B.0330 	1	 B.0224 - 137		
B.0331 	1	 B.0224 - 137		
B.0613 	2	 B.0224 - 145		
B.0813 	2	 B.0224 - 137	4	 B.0224 - 177

### ACCESSORIES

REF.	DESCRIPTION	N.	REF.	DESCRIPTION	N.
0311	Equerre dormant	2	8060	Paumelle Slim Rapid à deux corps	4*
A0280	Supplément equerre dormant	2	3065	Double bequille Italia	1
0311	Equerre ouvrant	4	2129.4	Cache cylindre Italia	2
A0280	Supplément equerre ouvrant	4			
PP2081.10	Embout battement central	1			

### JOINTS

REF.	DESCRIPTION	L	H	REF.	DESCRIPTION	L	H
IYS27-10	Central	1	3	CF4114	Vitrage interieur	2	4
SY3-247	Battement	1	4	CF4113	Vitrage exterieur	2	4
AG1503A	Joint brosse	2		<b>*VUILLEZ CONSULTER LE TABLEAU DE CHARGE</b>			

PORTE OUVERTURE INTERIEUR 2 VANTAUX

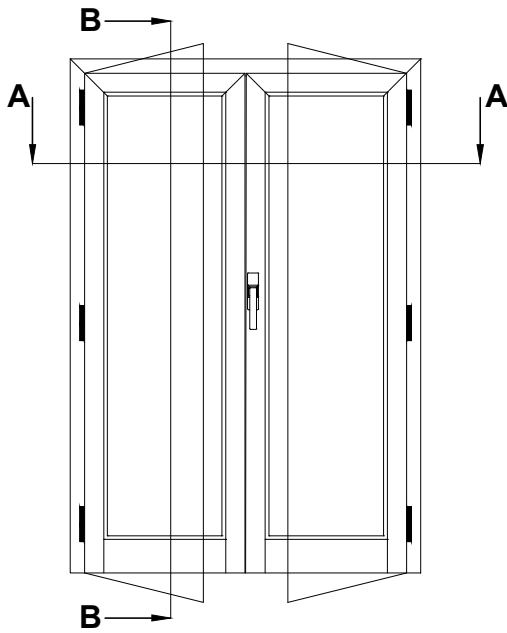

SEC. B-B

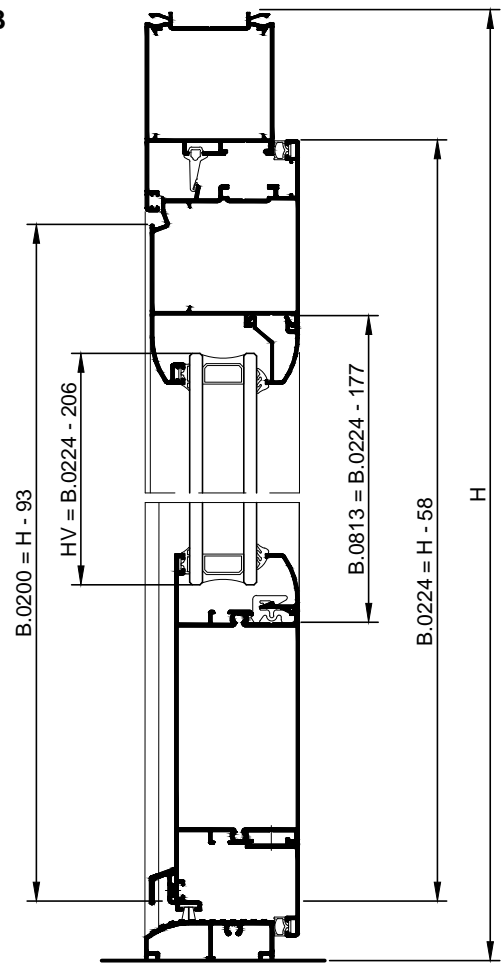





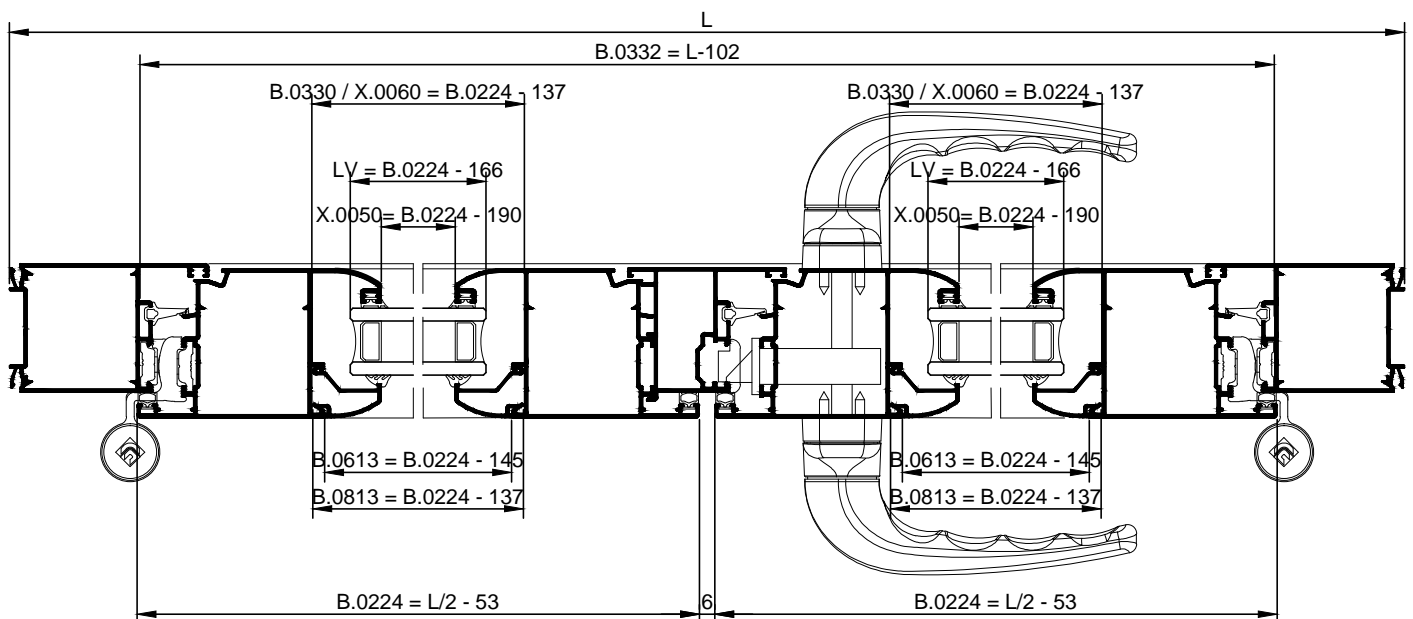



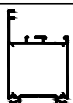
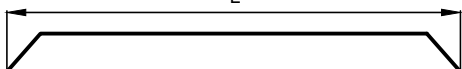
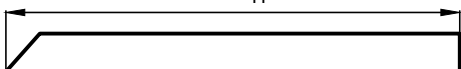
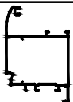
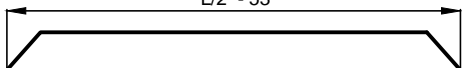
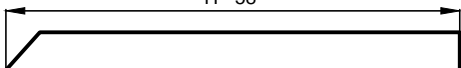
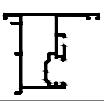
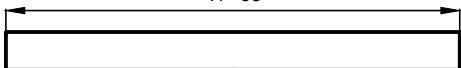
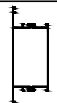
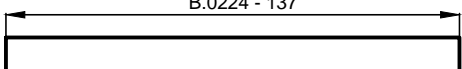

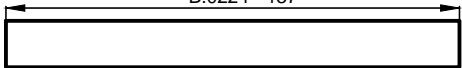
N.B.  
Épaisseur vitrage considérée 26mm  
L Vitrage = B.0224 - 166  
H Vitrage = B.0224 - 206

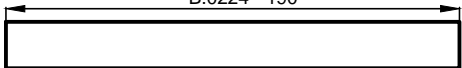
SEC. A-A

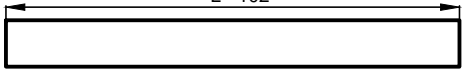

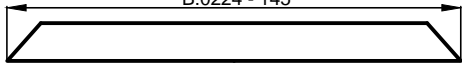
## PORTE OUVERTURE INTERIEUR 2 VANTAUX

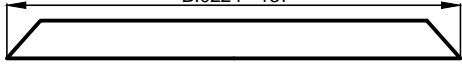
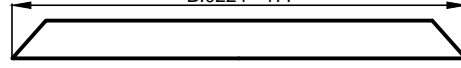
PROFILE	PCS	COUPE	PCS	COUPE
B.0125 	1	 L	2	 H
B.0224 	2	 L/2 - 53	4	 H - 58
B.0200 			1	 H - 93
B.0330 	2	 B.0224 - 137		
X.0060 	2	 B.0224 - 137		
X.0050 	2	 B.0224 - 190		
B.0332 	1	 L - 102		
B.0613 	2	 B.0224 - 145		
B.0813 	2	 B.0224 - 137	4	 B.0224 - 177

### ACCESSORIES

REF.	DESCRIPTION	N.	REF.	DESCRIPTION	N.
0311	Equerre dormant	2	8060	Paumelle Slim Rapid à deux corps	4*
A0280	Supplément equerre dormant	2	3065	Double bequille Italia	1
0311	Equerre ouvrant	4	2129.4	Cache cylindre Italia	2
A0280	Supplément equerre ouvrant	4			
PP2081.10	Embout battement central	1			

### JOINTS

REF.	DESCRIPTION	L	H	REF.	DESCRIPTION	L	H
IYS27-10	Central	1	3	CF4114	Vitrage interieur	2	4
SY3-247	Battement	1	4	CF4113	Vitrage exterieur	2	4
AG1503A	Joint brosse	2		<b>*VUILLEZ CONSULTER LE TABLEAU DE CHARGE</b>			

PORTE OUVERTURE EXTERIEUR 1 VANTAIL

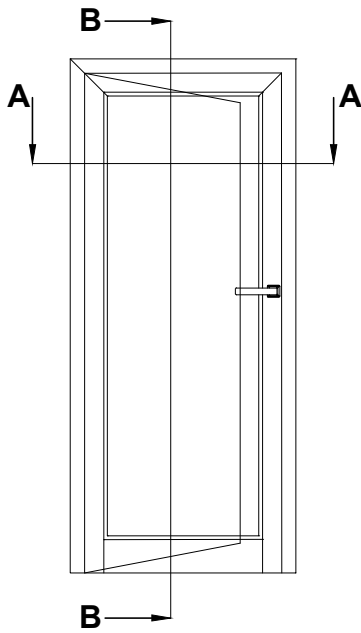

SEC. B-B

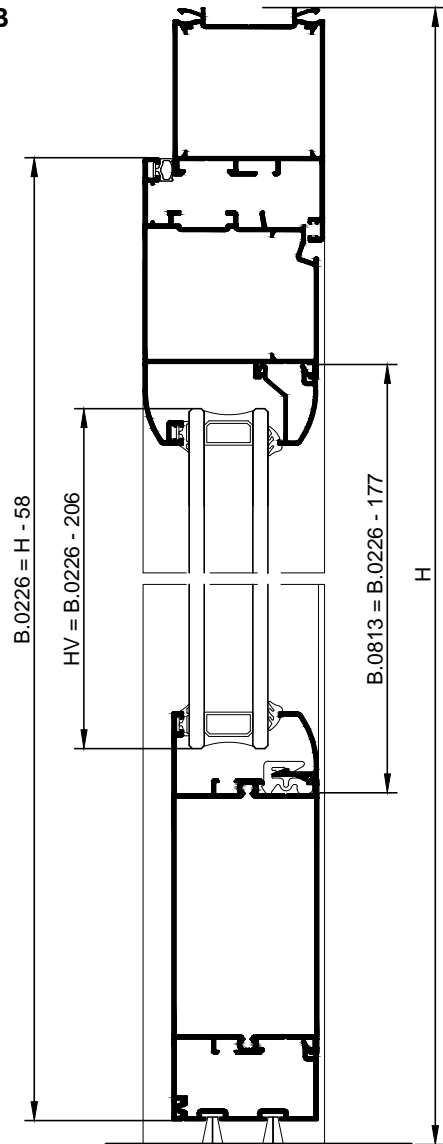





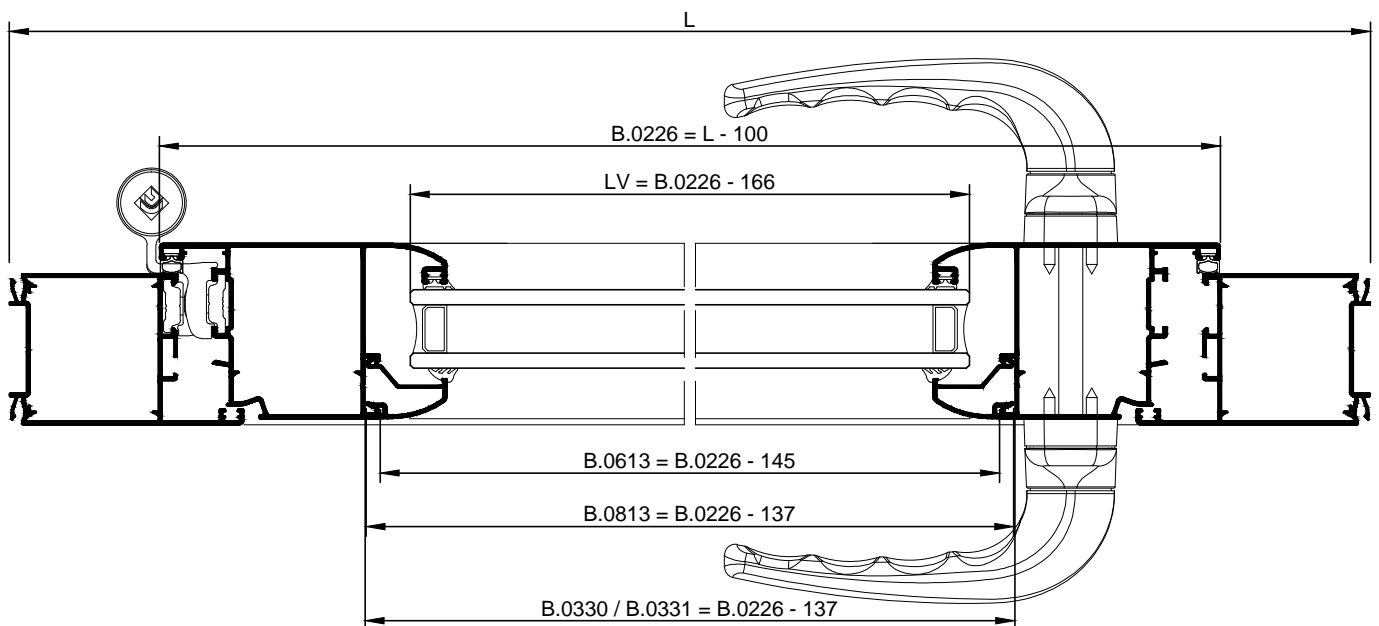

N.B.  
Épaisseur vitrage considérée 26mm  
L Vitrage = B.0224 - 166  
H Vitrage = B.0224 - 206

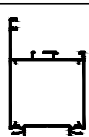
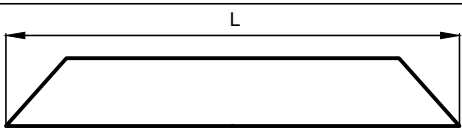
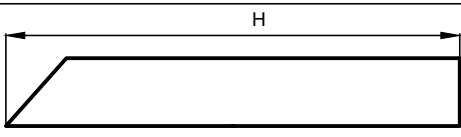
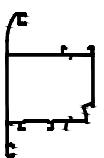
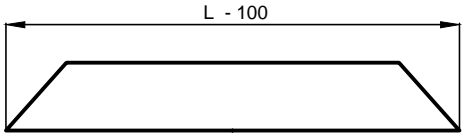
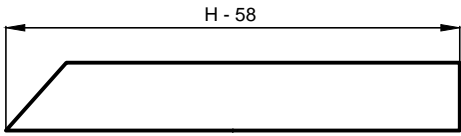
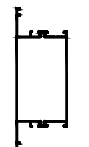
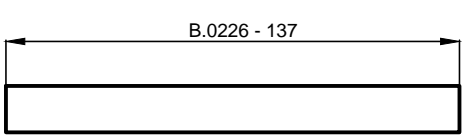
SEC. A-A

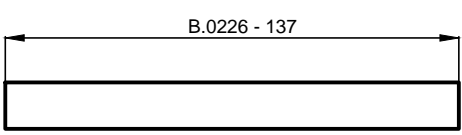

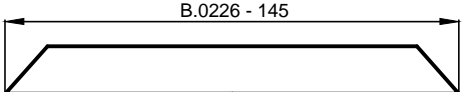
## PORTE OUVERTURE EXTERIEUR 1 VANTAIL

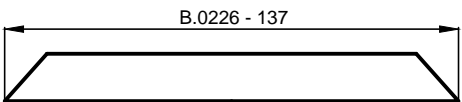
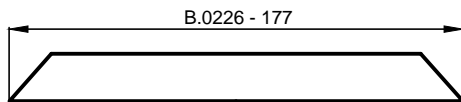
PROFILE	PCS	COUPE	PCS	COUPE
B.0125 	1	 L	2	 H
B.0226 	1	 L - 100	2	 H - 58
B.0330 	1	 B.0226 - 137		
B.0331 	1	 B.0226 - 137		
B.0613 	1	 B.0226 - 145		
B.0813 	1	 B.0226 - 137	2	 B.0226 - 177

### ACCESSORIES

REF.	DESCRIPTION	N.	REF.	DESCRIPTION	N.
0311	Equerre dormant	2	3065	Double bequille Italia	1
A0280	Supplément equerre dormant	2	2129.4	Cache cylindre Italia	2
0311	Equerre ouvrant	2			
A0280	Supplément equerre ouvrant	2			
8060	Paumelle Slim Rapid à deux corps	2*			

### JOINTS

REF.	DESCRIPTION	L	H	REF.	DESCRIPTION	L	H
IYS27-10	Central	1	2	CF4114	Vitrage interieur	2	2
SY3-247	Battement	1	2	CF4113	Vitrage exterieur	2	2
AG1503A	Joint brosse	2		<b>*VUILLEZ CONSULTER LE TABLEAU DE CHARGE</b>			

PORTE OUVERTURE INTERIEUR 2 VANTAUX

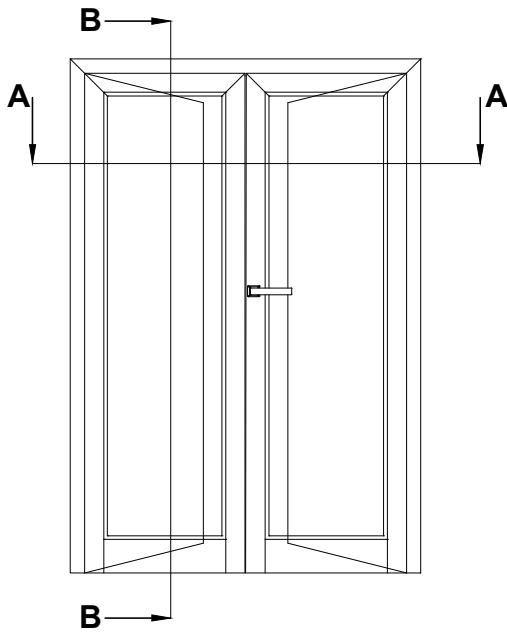

SEC. B-B

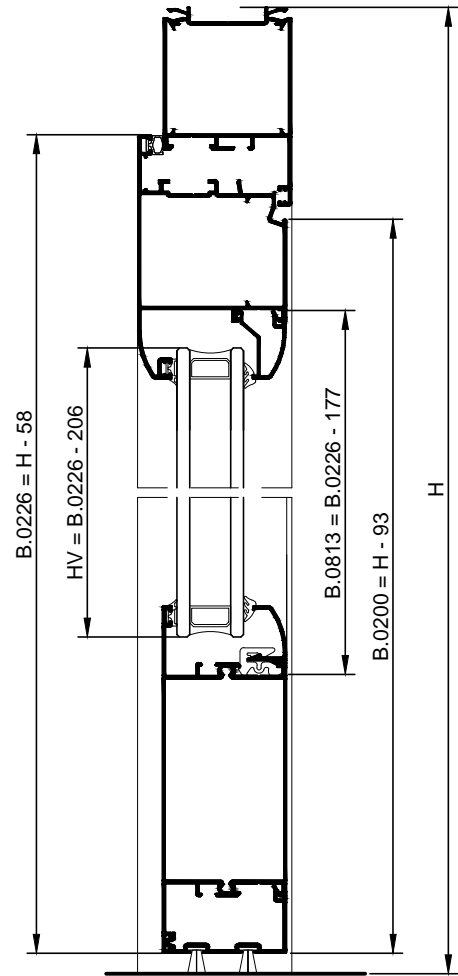





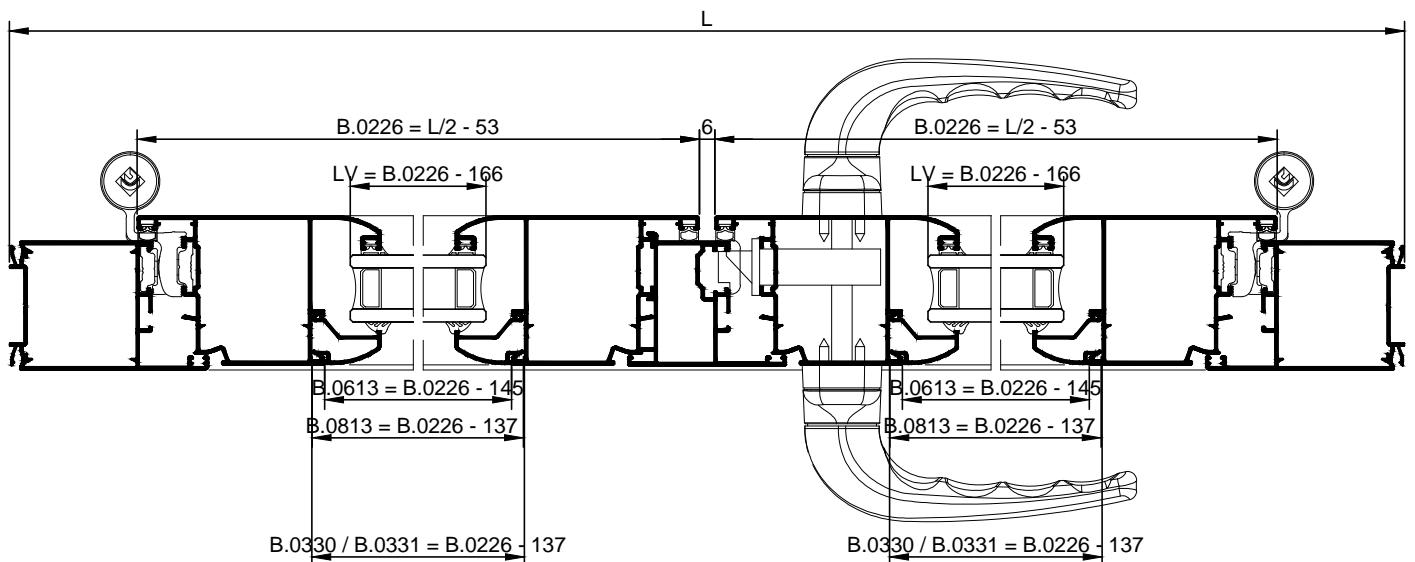

N.B.  
 Épaisseur vitrage considérée 26mm  
 L Vitrage = B.0224 - 166  
 H Vitrage = B.0224 - 206

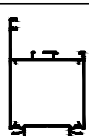
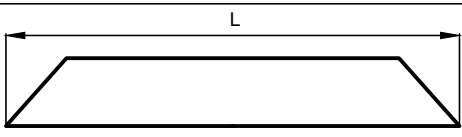
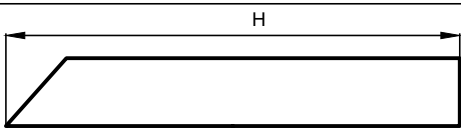
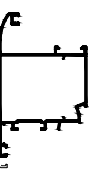
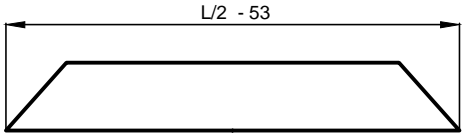
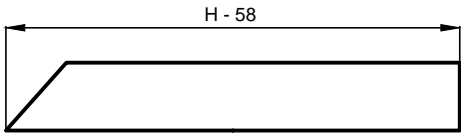
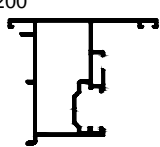
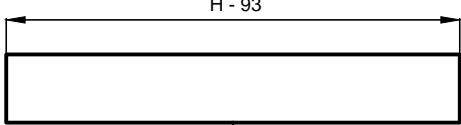
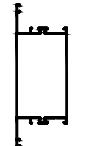
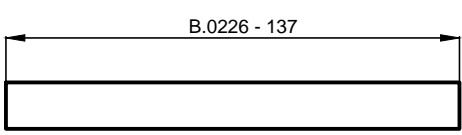
SEC. A-A

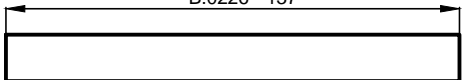

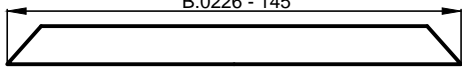
## PORTE OUVERTURE INTERIEUR 2 VANTAUX

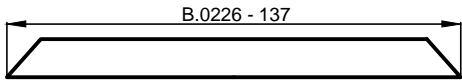
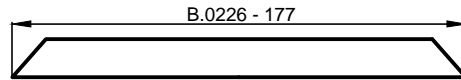
PROFILE	PCS	COUPE	PCS	COUPE
B.0125 	1	 L	2	 H
B.0226 	2	 L/2 - 53	4	 H - 58
B.0200 			1	 H - 93
B.0330 	1	 B.0226 - 137		
B.0331 	1	 B.0226 - 137		
B.0613 	2	 B.0226 - 145		
B.0813 	2	 B.0226 - 137	4	 B.0226 - 177

### ACCESSORIES

REF.	DESCRIPTION	N.	REF.	DESCRIPTION	N.
0311	Equerre dormant	2	8060	Paumelle Slim Rapid à deux corps	4*
A0280	Supplément equerre dormant	2	3065	Double bequille Italia	1
0311	Equerre ouvrant	4	2129.4	Cache cylindre Italia	2
A0280	Supplément equerre ouvrant	4			
PP2081.10	Embout battement central	1			

### JOINTS

REF.	DESCRIPTION	L	H	REF.	DESCRIPTION	L	H
IYS27-10	Central	1	3	CF4114	Vitrage interieur	2	4
SY3-247	Battement	1	4	CF4113	Vitrage exterieur	2	4
AG1503A	Joint brosse	2		<b>*VUILLEZ CONSULTER LE TABLEAU DE CHARGE</b>			

FENETRE A L'ITALIENNE

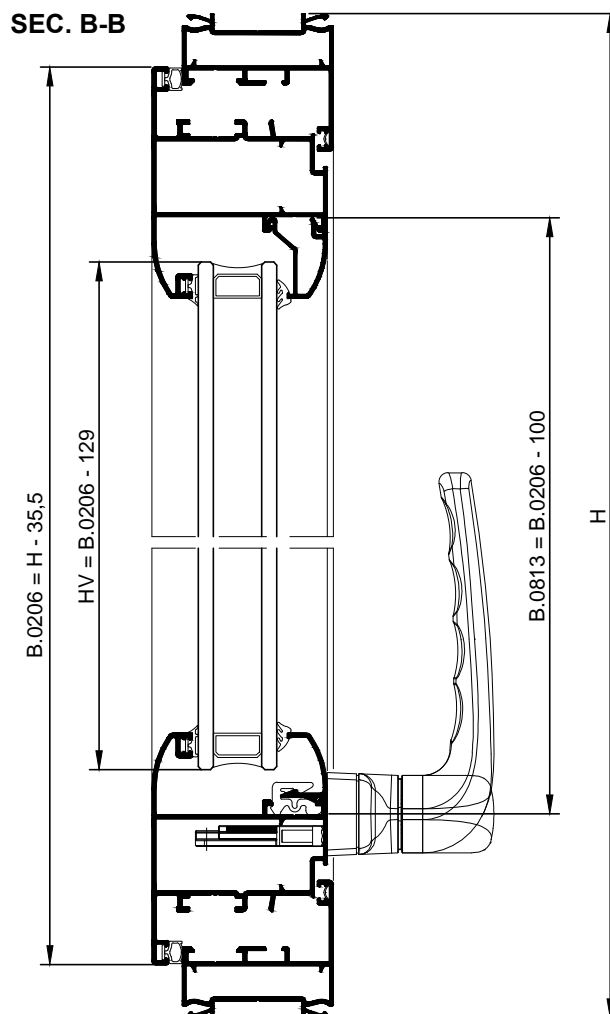
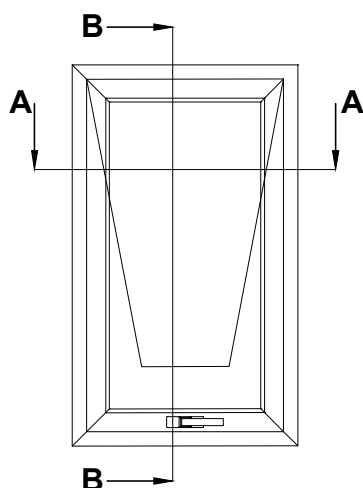



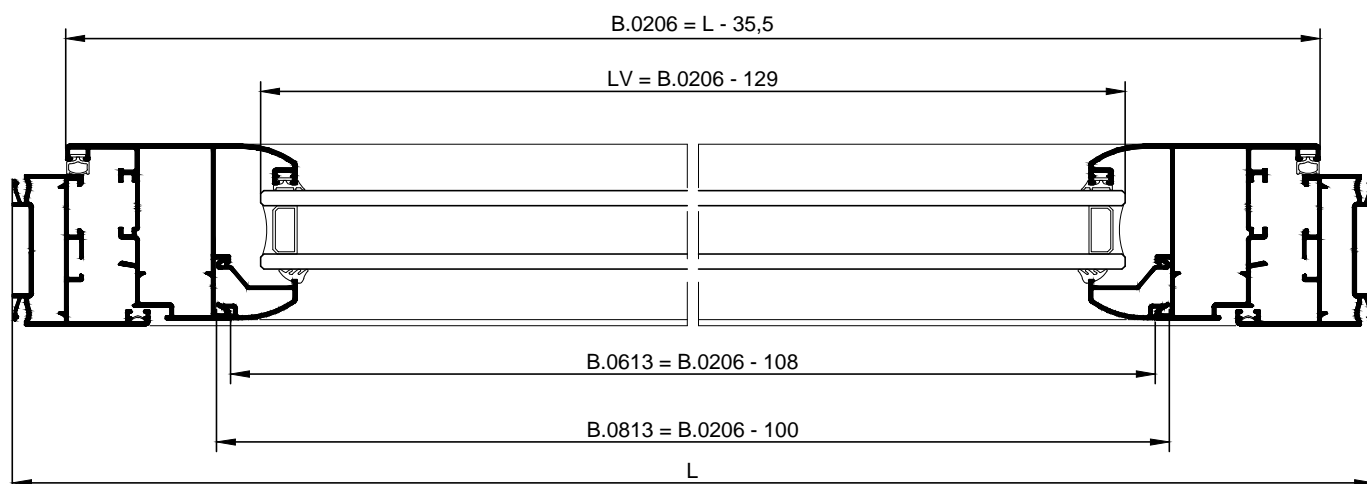

N.B.  
Épaisseur vitrage considérée 26mm  
L Vitrage = B.0204 - 102  
H Vitrage = B.0204 - 102

SEC. A-A



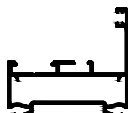
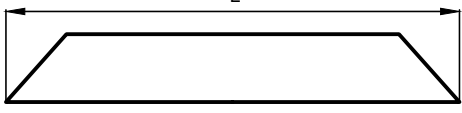
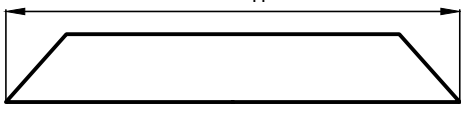
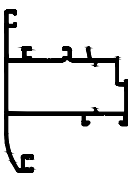
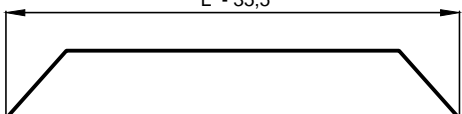
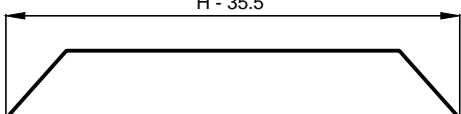

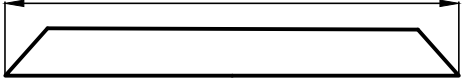
## FENETRE A L'ITALIENNE

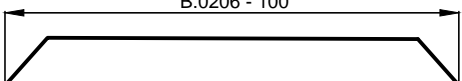
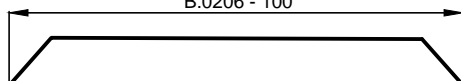
PROFILE	PCS	COUPE	PCS	COUPE
B.0105 	2	 L	2	 H
B.0206 	2	 L - 35,5	2	 H - 35,5
B.0613 	1	 B.0206 - 108		
B.0813 	1	 B.0206 - 100	2	 B.0206 - 100

## ACCESSORIES

REF.	DESCRIPTION	N.	REF.	DESCRIPTION	N.
0311	Equerre dormant	4	6420E.25	Pivot de jonction (L=25mm)	2
0311	Equerre ouvrant	4	4207.21	Point fermeture additionelle	2
A0280	Supplément equerre ouvrant	2			
3420.71	Paumelle à peigne	2*			
6028.3	Crémone Comfort Plus	1			

## JOINTS

REF.	DESCRIPTION	L	H	REF.	DESCRIPTION	L	H
IYS27-10	Central	2	2	CF4114	Vitrage interieur	2	2
SY3-247	Battement	2	2	CF4113	Vitrage exterieur	2	2

\*VUILLEZ CONSULTER LE TABLEAU DE CHARGE

PORTE OUVERTURE COULISSANT PARALLELE 1 VANTAIL+FIXE

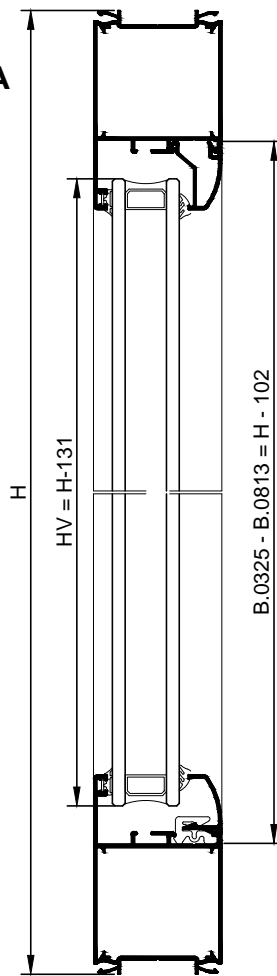
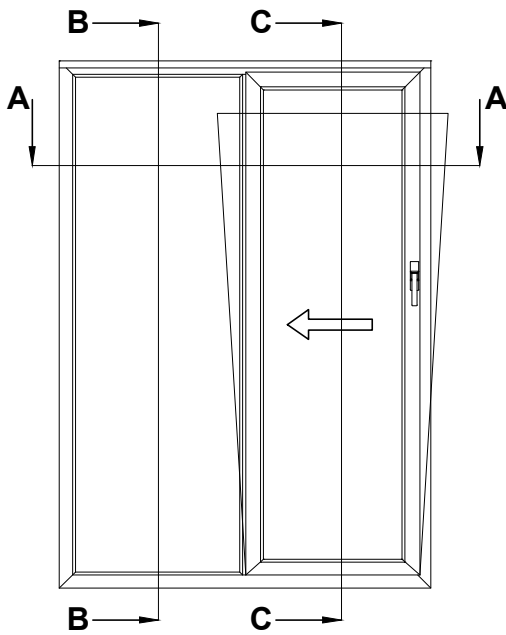

SEC. B-B

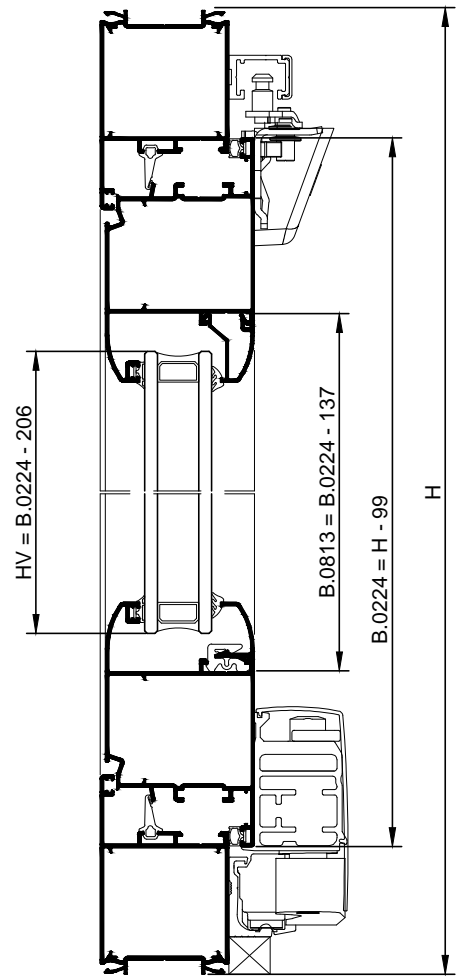

SEC. C-C

N.B.  
Épaisseur vitrage considérée 26mm  
L Vitrage = B.0224 - 166  
H Vitrage = B.0224 - 206

N.B.  
Épaisseur vitrage considérée 26mm  
L Vitrage Fixe = L/2 - 101  
H Vitrage Fixe = H - 131

SEC. A-A

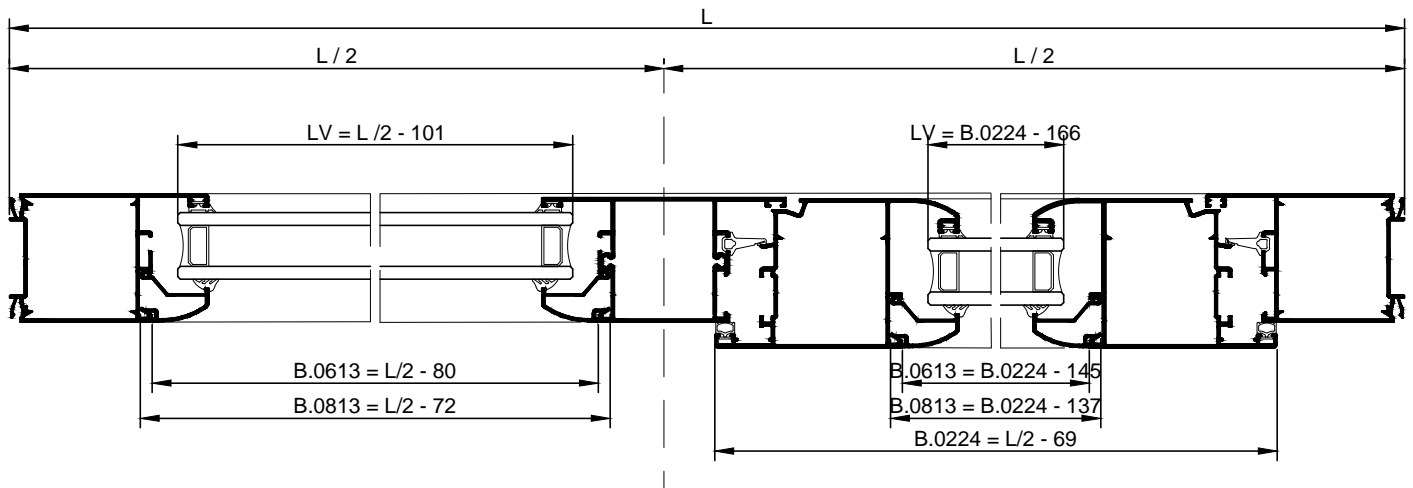

\*POUR PLUS D'INFORMATIONS CONCERNANT L'USINAGE, VEUILLEZ CONSULTER LE SCHEMA DE MONTAGE SP160

## PORTE OUVERTURE COULISSANT PARALLELE 1 VANTAIL+FIXE

PROFILE	PCS	COUPE	PCS	COUPE
B.0125 	2		2	
B.0224 	2		2	
B.0325 			1	
B.0613 	1			
B.0613 	1			
B.0813 	1		1	
B.0813 	1		1	

### ACCESSORIES

REF.	DESCRIPTION	N.	REF.	DESCRIPTION	N.
0311	Equerre dormant	2	----	Manoeuvre et fermeture	
A0281	Supplément equerre dormant	2			
0311	Equerre ouvrant	4			
A0280	Supplément equerre ouvrant	4			

### JOINTS

REF.	DESCRIPTION	L	H	REF.	DESCRIPTION	L	H
IYS27-10	Central	2	2	CF4114	Vitrage interieur	2	4
SY3-247	Battement	2	2	CF4113	Vitrage exterieur	2	4

\*POUR PLUS D'INFORMATIONS CONCERNANT L'USINAGE, VEUILLEZ CONSULTER LE SCHEMA DE MONTAGE SP160

EQUERRE

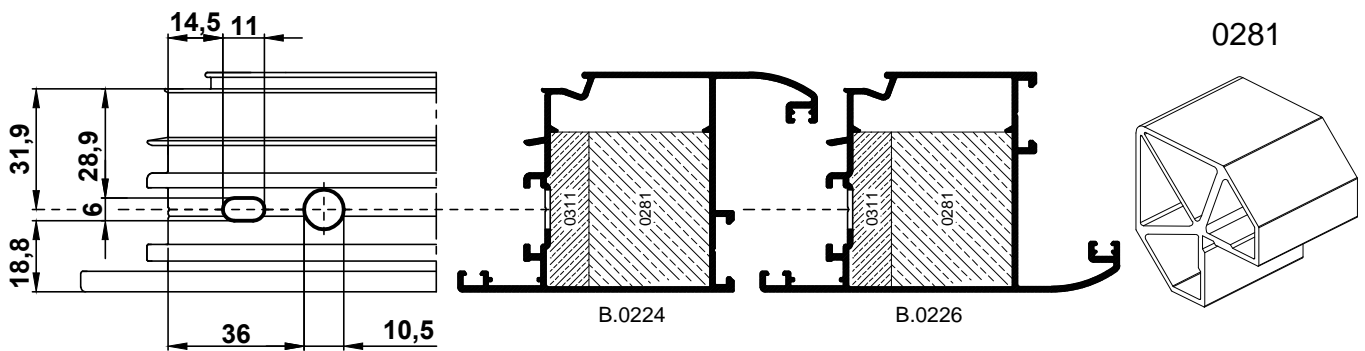
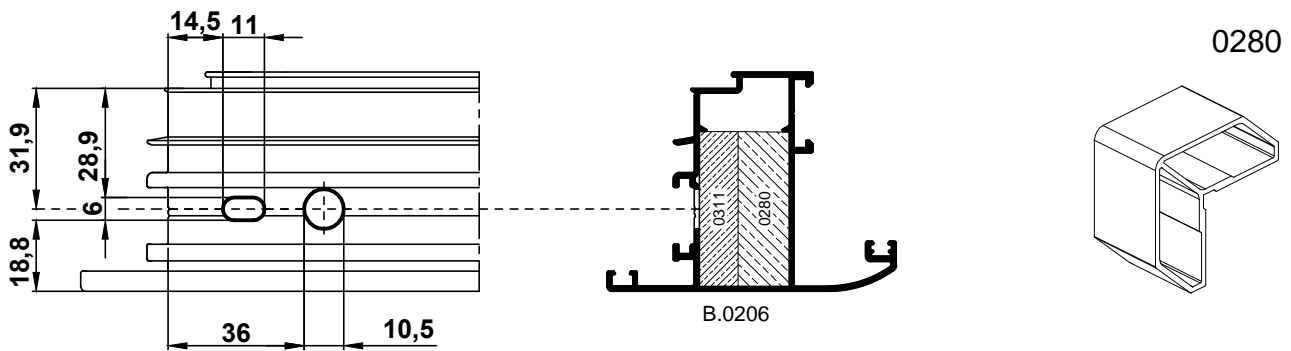
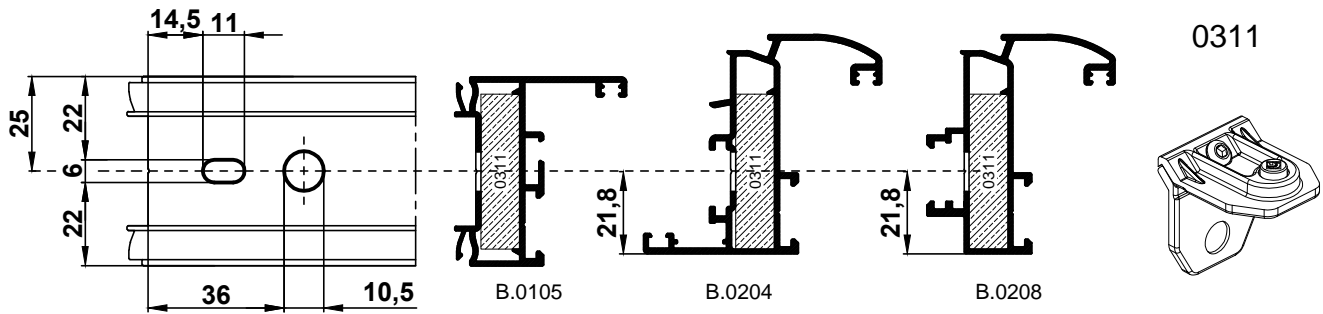

Outil : Bloc outil / Perceuse

POIGNEE

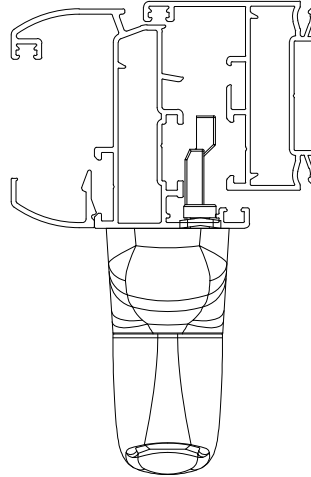
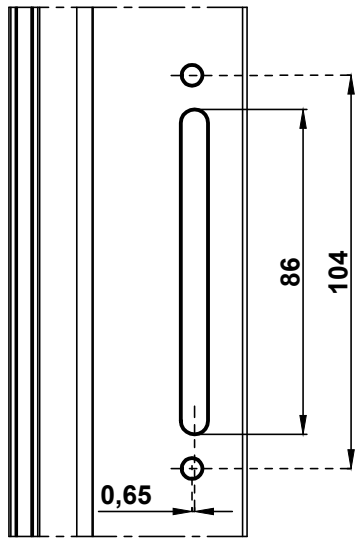
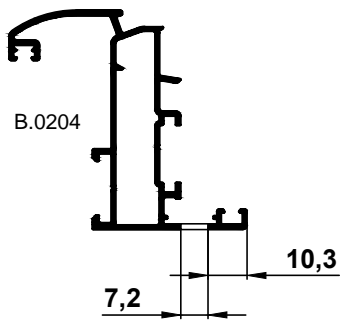

6036.20D  
6036.20S

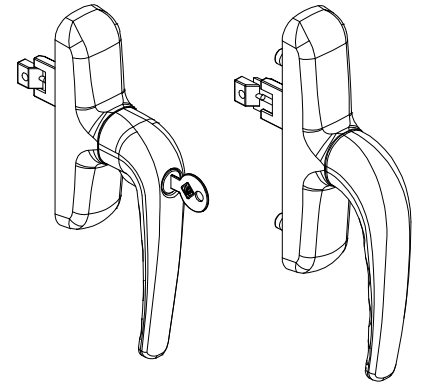

6011.10

6010.21

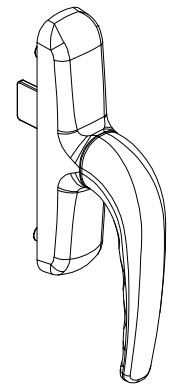

Outil : Perceuse

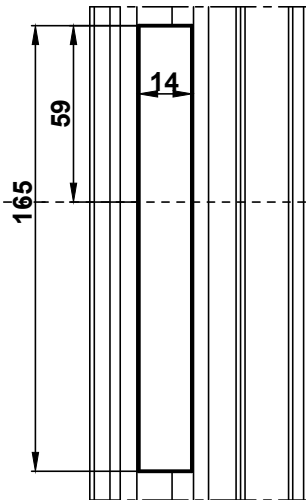
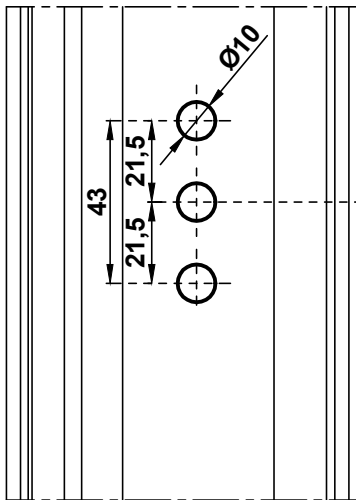

Axe  
usinage

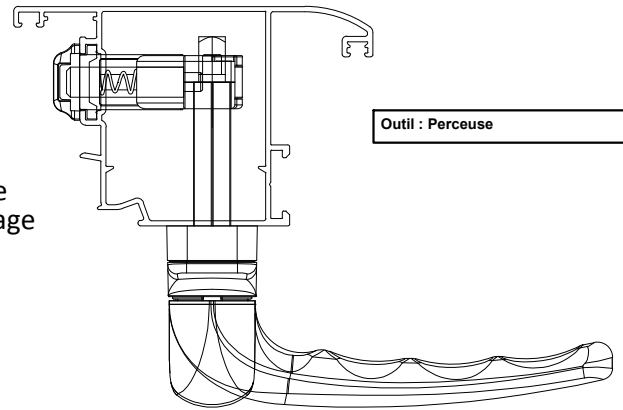

Outil : Perceuse

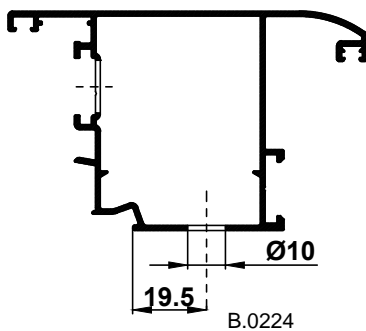

B.0224

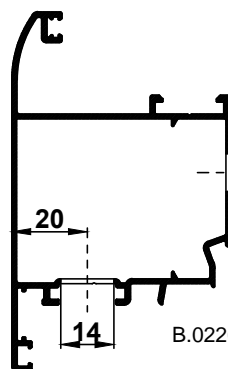

B.0226

3626.2

6420E.31

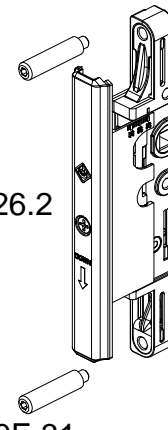

3075.1

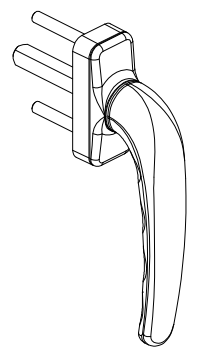

POIGNEE

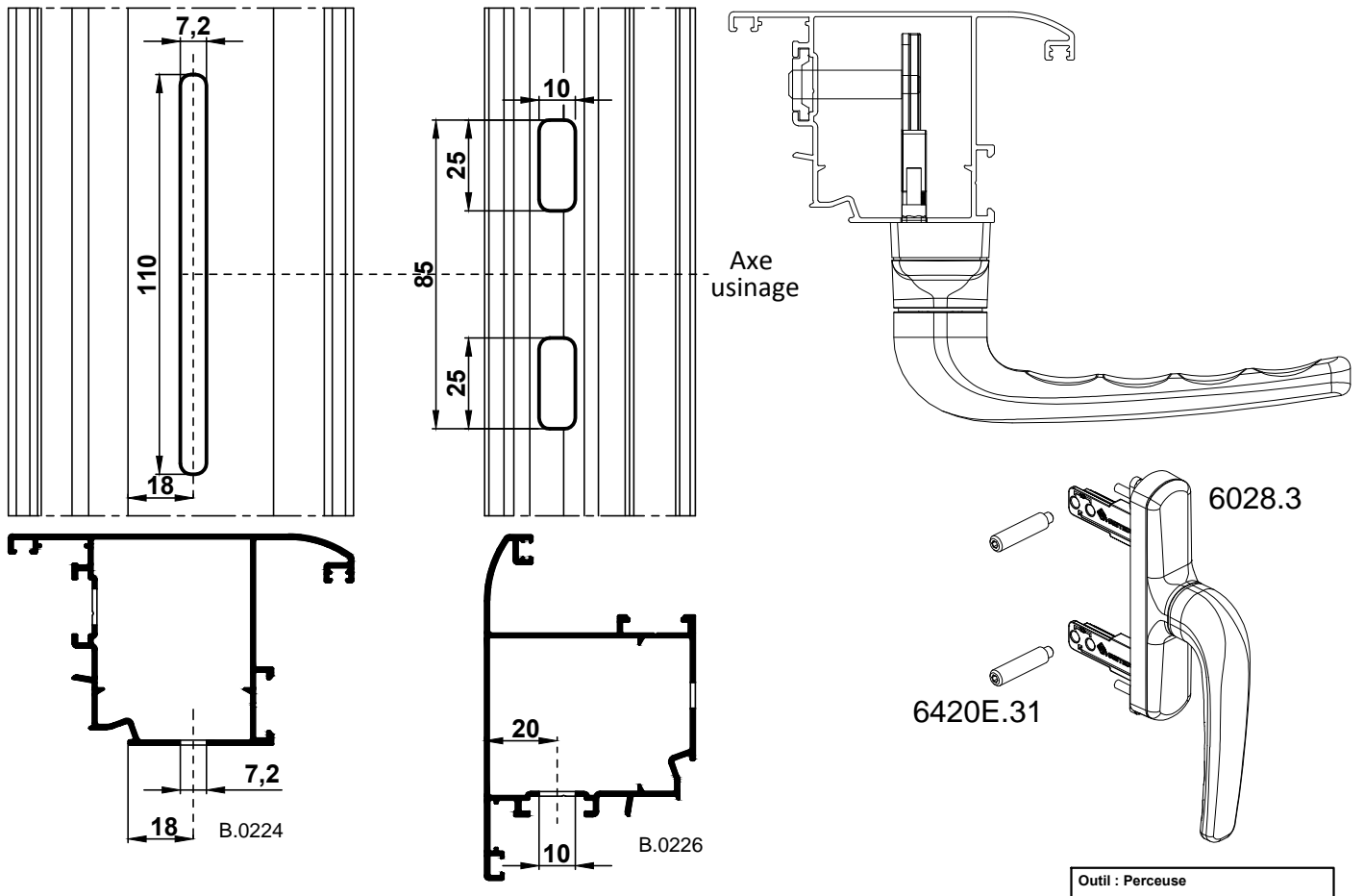

BLOC D'ASSEMBLAGE

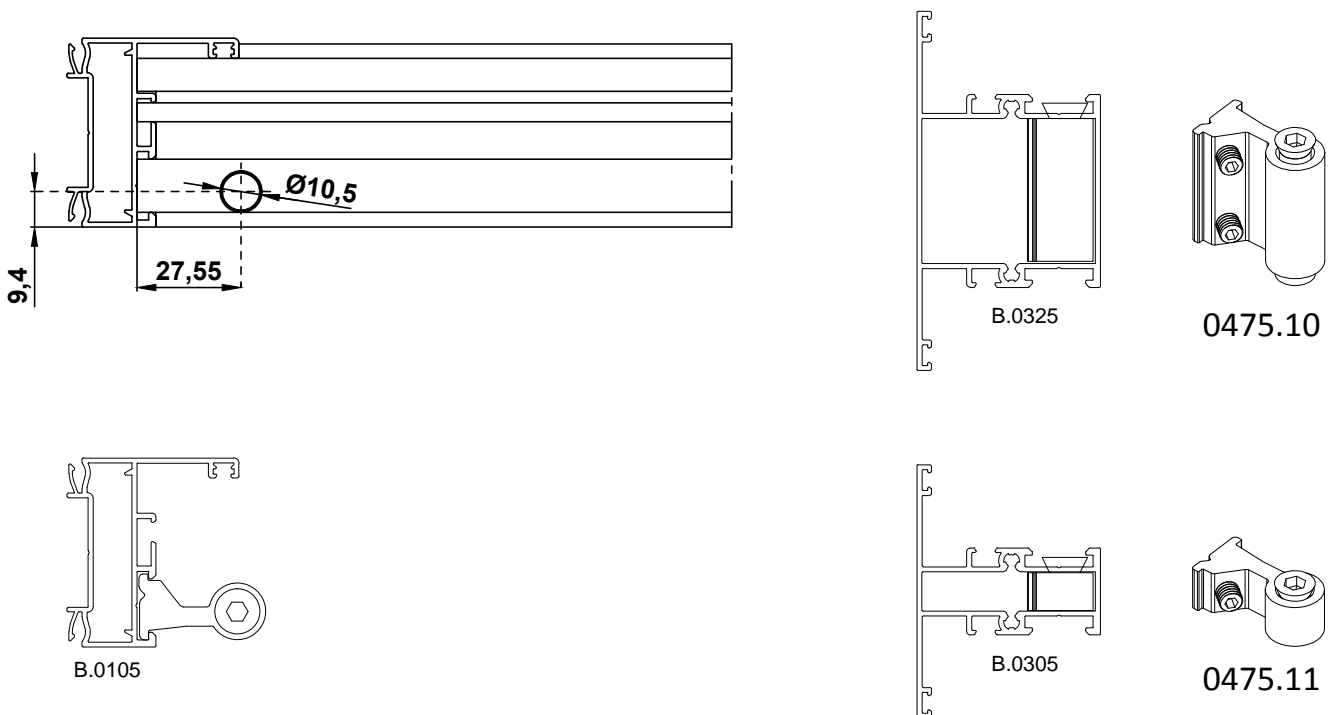

BUSETTE D' EVACUATION

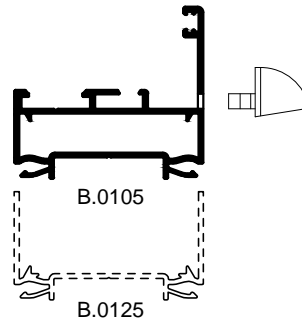
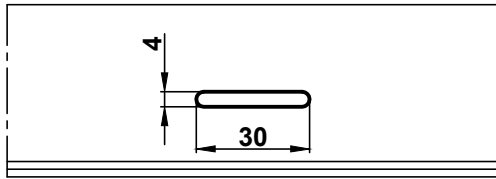

2145

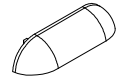

Outil : Perceuse

VERIN DE POSE

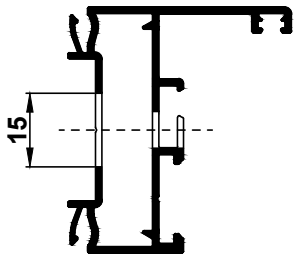

B.0105

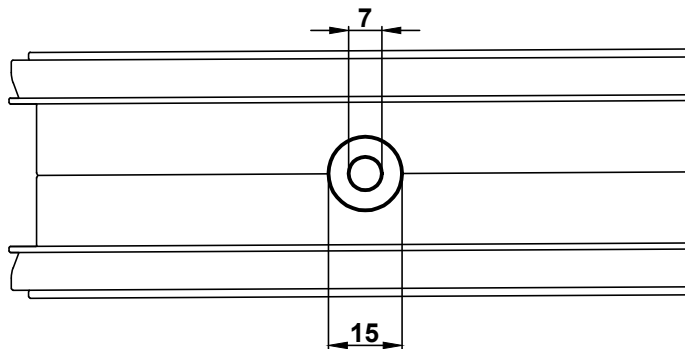

2133

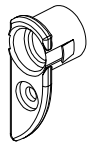

Outil : Perceuse

USINAGE ANGLE

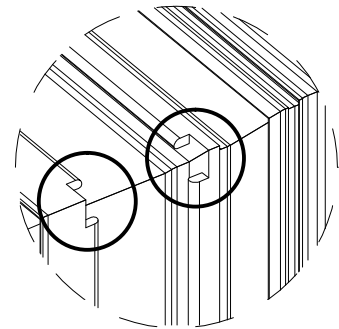
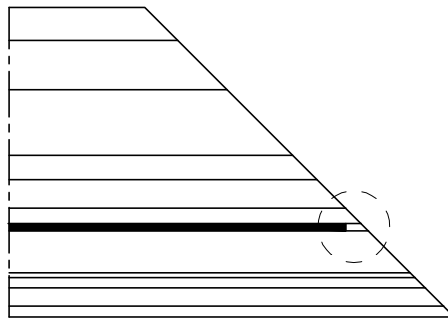
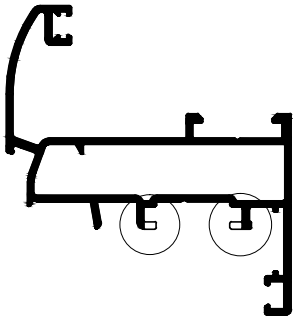

Outil : Perceuse / bloc outil

USINAGE TRINGLE

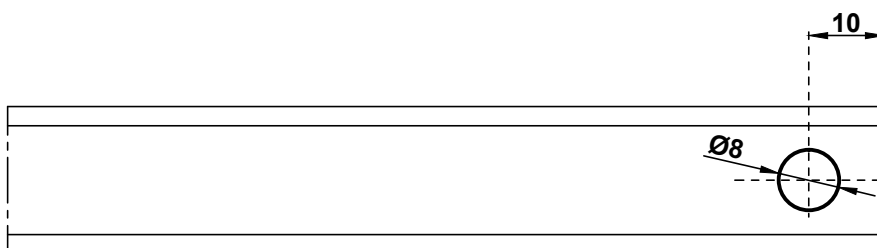

2010.2

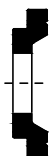

Outil : Bloc outil / Perceuse